

Manuscript Number:

Title: A Polynomial Time Subsumption Algorithm for  $\mathcal{EL}^{\text{bot}}$  under Rational Closure

Article Type: Full Length Article

Keywords: Description Logics; Defeasible Reasoning; Nonmonotonic Reasoning; Rational Closure

Corresponding Author: Dr. Umberto Straccia,

Corresponding Author's Institution: CNR

First Author: Umberto Straccia

Order of Authors: Umberto Straccia; Giovanni Casini; Thomas Meyer

Abstract: In this paper we consider Description Logics (DLs) under Rational Closure (RC), a well-known framework for non-monotonic reasoning in DLs. Specifically, we address the concept subsumption decision problem under RC for the DL  $\mathcal{EL}^{\text{bot}}$ , a notable DL representative of the OWL profile OWL EL.

Previous subsumption decision procedures for DLs under RC have been defined for more expressive DLs. These procedures, however, do not scale down in the sense that they remain exponential for  $\mathcal{EL}^{\text{bot}}$ , even if the monotonic subsumption decision problem is polynomial. Our main contribution here is to define a polynomial time subsumption procedure for  $\mathcal{EL}^{\text{bot}}$  under RC. We also adapt it to known extensions of RC for DLs, such as Lexicographic Closure, Defeasible Inheritance-based DLs, and two versions of Relevant Closure. Since the basic language requirement is to have conjunction on the left-hand side of so-called Generalised Concept Inclusions, we show that our procedure can be adapted to any other DL having this feature as well.

Suggested Reviewers: Piero Bonatti  
piero.bonatti@unina.it  
expert

Laura Giordano  
laura.giordano@mfh.unipmn.it  
Expert

Nicola Olivetti  
nicola.olivetti@univ-amu.fr

Opposed Reviewers:

# A Polynomial Time Subsumption Algorithm for $\mathcal{EL}^\perp$ under Rational Closure

Giovanni Casini<sup>a,b</sup>, Umberto Straccia<sup>c</sup>, Thomas Meyer<sup>d</sup>

<sup>a</sup>*University of Luxembourg, Luxembourg*

<sup>b</sup>*CAIR, University of Pretoria, South Africa*

<sup>c</sup>*ISTI, Consiglio Nazionale delle Ricerche, Italy*

<sup>d</sup>*CAIR, University of Cape Town, South Africa*

---

## Abstract

In this paper we consider Description Logics (DLs) under Rational Closure (RC), a well-known framework for non-monotonic reasoning in DLs. Specifically, we address the concept subsumption decision problem under RC for the DL  $\mathcal{EL}^\perp$ , a notable DL representative of the OWL profile OWL EL.

Previous subsumption decision procedures for DLs under RC have been defined for more expressive DLs. These procedures, however, do not scale down in the sense that they remain exponential for  $\mathcal{EL}^\perp$ , even if the monotonic subsumption decision problem is polynomial. Our main contribution here is to define a polynomial time subsumption procedure for  $\mathcal{EL}^\perp$  under RC. We also adapt it to known extensions of RC for DLs, such as Lexicographic Closure, Defeasible Inheritance-based DLs, and two versions of Relevant Closure. Since the basic language requirement is to have conjunction on the left-hand side of so-called Generalised Concept Inclusions, we show that our procedure can be adapted to any other DL having this feature as well.

*Keywords:* Description Logics, Defeasible Reasoning, Nonmonotonic Reasoning, EL, Rational Closure

---

## 1. Introduction

Description logics (DLs) [3] provide the logical foundation of formal ontologies of the OWL family [48].

---

*Email addresses:* giovanni.casini@uni.lu (Giovanni Casini),  
umberto.straccia@isti.cnr.it (Umberto Straccia), tmeyer@cs.uct.ac.za (Thomas Meyer)

1  
2  
3  
4  
5  
6  
7 Among the various extensions proposed to enhance the representational capabilities of DLs, endowing them with non-monotonic features is still a main issue, as  
8 documented by the past 20 years of technical development [4, 5, 7, 10, 13, 14, 18,  
9 20, 22, 23, 24, 26, 31, 34, 37, 41, 45, 46, 52, 54]. We refer the reader to the recent  
10 work of Bonatti et al. [7] and Giordano et al. [31] for discussions about the various  
11 approaches.  
12

13  
14 We recall that a typical problem that can successfully be addressed using non-  
15 monotonic formalisms is reasoning with ontologies in which some classes are excep-  
16 tional w.r.t. some properties of their superclasses, as illustrated next [53].  
17

18 **Example 1.** *We know that blood cells of a cow, avian red blood cells and mammalian*  
19 *red blood cells are vertebrate red blood cells, and that vertebrate red blood cells nor-*  
20 *mally have a cell membrane. We also know that vertebrate red blood cells normally*  
21 *have a nucleus, but that mammalian red blood cells normally don't.*  
22

23  
24 A classical formalisation of the ontology above would imply that mammalian red  
25 blood cells do not exist, since, being a subclass of vertebrate red blood cells, they  
26 would have a nucleus, but they are an atypical subclass that does not have a nucleus.  
27 Therefore, mammalian red blood cells would and would not have a nucleus at the  
28 same time. Unlike a classical approach, the use of a non-monotonic formalism may  
29 allow to deal with such exceptional classes.  
30

31  
32 Between the various proposals to inject non-monotonicity into DLs, the prefer-  
33 ential approach seems to be a particularly promising one, mostly because it is based  
34 on one of the most comprehensive and successful frameworks for non-monotonic  
35 reasoning in the propositional case, namely the *KLM approach* [40]. One of the  
36 main constructions in the preferential approach is *Rational Closure* (RC) [43]. RC  
37 is a procedure that has some interesting properties: the conclusions are intuitive,  
38 and the decision procedure can be reduced to a series of classical decision prob-  
39 lems, sometimes preserving the computational complexity of the classical decision  
40 problem too. In recent years there has been a flurry of activity about DLs and  
41 RC [12, 16, 17, 18, 19, 20, 21, 29, 32, 33, 34, 35, 36].  
42

43  
44 As pointed out by Bonatti et al. [7], usually, non-monotonic extensions do not  
45 preserve the tractability of low-complexity DLs [9, 15, 18, 25, 30, 45],<sup>1</sup> which is also  
46 the case for current algorithms for DLs under RC. Specifically, procedures developed  
47 so far to reason with DLs under RC need a DL language that is closed under the  
48 propositional operators. A drawback of such a requirement is that we cannot apply  
49 RC directly to low-complexity DL languages, such as  $\mathcal{EL}^\perp$  [2] whose subsumption  
50

51  
52  
53  
54 

---

<sup>1</sup>Among the few exceptions are the proposals by Bonatti et al. [7, 9].  
55

1  
2  
3  
4  
5  
6  
7  
8  
9  
10  
11  
12  
13  
14  
15  
16  
17  
18  
19  
20  
21  
22  
23  
24  
25  
26  
27  
28  
29  
30  
31  
32  
33  
34  
35  
36  
37  
38  
39  
40  
41  
42  
43  
44  
45  
46  
47  
48  
49  
50  
51  
52  
53  
54  
55  
56  
57  
58  
59  
60  
61  
62  
63  
64  
65

decision problem is in P, without losing the computational benefit of such languages. That is, these procedures do not scale down, in the sense that they remain exponential for  $\mathcal{EL}^\perp$  [18].

The main contribution of our work is to show here that, despite the expressive limitations of  $\mathcal{EL}^\perp$ , we can effectively define a procedure that implements RC for  $\mathcal{EL}^\perp$  in such a way that deciding subsumption under RC for  $\mathcal{EL}^\perp$  remains polynomial. This result is of particular importance as  $\mathcal{EL}^\perp$  is closely related to the semantic web language standard OWL EL [50], an OWL 2 profile [49]. We then also illustrate how to adapt our procedure to various extensions of RC for DLs, such as Lexicographic Closure [21], Defeasible Inheritance-based DLs [19], and Relevant Closures [16]. Eventually, as the basic language requirement is to have conjunction on the left-hand side of so-called Generalised Concept Inclusion [3], our procedure can be adapted to any other DL having this feature as well.

We proceed as follows: Section 2 introduces the DL  $\mathcal{EL}^\perp$  and Rational Closure; Section 3 contains the main result of the paper, that is, a polynomial procedure to decide subsumption under RC for defeasible  $\mathcal{EL}^\perp$ ; in Section 4, we adapt our procedure to various extensions of RC for DLs. Section 5 concludes and addresses related work.

All relevant proofs are in the appendix.

## 2. Preliminaries

In the following we briefly present the DL  $\mathcal{EL}^\perp$  and the previously proposed procedure to decide subsumption under Rational Closure for the DL  $\mathcal{ALC}$ .

### 2.1. The Description Logic $\mathcal{EL}^\perp$

$\mathcal{EL}^\perp$  is the DL  $\mathcal{EL}$  with the addition of the empty concept  $\perp$  [2]. Note that considering  $\mathcal{EL}$  only would not make sense in our case as  $\mathcal{EL}$  knowledge bases are always concept-satisfiable, while the notion of defeasible reasoning is built over a notion of conflict (see Example 1) which needs to be expressible in the language.

The vocabulary is given by a set of *atomic concepts*  $\mathbf{N}_{\mathcal{C}} = \{A_1, A_2, \dots\}$  and a set of *atomic roles*  $\mathbf{N}_{\mathcal{R}} = \{r_1, r_2, \dots\}$ . Concept expressions  $C, D, \dots$  are built according to the following syntax:

$$C, D \rightarrow A \mid \top \mid \perp \mid C \sqcap D \mid \exists r.C .$$

An *ontology*  $\mathcal{T}$  (or *TBox*, or *knowledge base*) is a finite set of *Generalised Concept Inclusion* (GCI) axioms  $C \sqsubseteq D$  ( $C$  is subsumed by  $D$ ), meaning that all the objects in the concept  $C$  are also in the concept  $D$ . We use the expression  $C = D$  as

1  
2  
3  
4  
5  
6 a shorthand for having both  $C \sqsubseteq D$  and  $D \sqsubseteq C$ . An *interpretation* is a pair  
7  $\mathcal{I} = \langle \Delta^{\mathcal{I}}, \cdot^{\mathcal{I}} \rangle$ , where  $\Delta^{\mathcal{I}}$  is a non-empty set, called *interpretation domain* and  $\cdot^{\mathcal{I}}$  is an  
8 *interpretation function*  
9

- 10 1. mapping atomic concepts  $A$  into subsets  $A^{\mathcal{I}} \subseteq \Delta^{\mathcal{I}}$ ;
- 11 2. mapping roles  $r$  into a subset  $r^{\mathcal{I}} \subseteq \Delta^{\mathcal{I}} \times \Delta^{\mathcal{I}}$ .

12  
13  
14 An interpretation  $\mathcal{I}$  *satisfies (is a model of)*  $C \sqsubseteq D$  if  $C^{\mathcal{I}} \subseteq D^{\mathcal{I}}$ , denoted  $\mathcal{I} \models C \sqsubseteq D$ .  
15  $\mathcal{I}$  *satisfies (is a model of)* an ontology  $\mathcal{T}$  if it satisfies each axiom in it. An axiom  $\alpha$   
16 is *entailed* by a  $\mathcal{T}$  if any model of  $\mathcal{T}$  is a model of  $\alpha$ , denoted as  $\mathcal{T} \models \alpha$ .  
17  
18

## 19 2.2. Rational Closure in $\mathcal{ALC}$

20 We briefly recap RC for the DL  $\mathcal{ALC}$  [12, 18, 36], which in turn is based on its  
21 original formulation for Propositional Logic [43]. As mentioned earlier, there is work  
22 addressing RC for DLs as well [29, 33, 32, 34].  
23

24 A *defeasible GCI* axiom is of the form  $C \sqsubset D$ , that is read as ‘Typically, an  
25 instance of  $C$  is also an instance of  $D$ ’. We extend ontologies with a *DBox*  $\mathcal{D}$ ,  
26 i.e. finite set of defeasible GCIs and denote an ontology as  $\mathcal{K} = \langle \mathcal{T}, \mathcal{D} \rangle$ , where  $\mathcal{T}$  is  
27 a TBox and  $\mathcal{D}$  is a DBox.  
28  
29

30 **Example 2.** We can formalise the information in Example 1 with the following  
31 ontology  $\mathcal{K} = \langle \mathcal{T}, \mathcal{D} \rangle$  with  
32

$$33 \quad \mathcal{T} = \{ \text{CRBC} \sqsubseteq \text{MRBC},$$

$$34 \quad \quad \text{ARBC} \sqsubseteq \text{VRBC},$$

$$35 \quad \quad \text{MRBC} \sqsubseteq \text{VRBC},$$

$$36 \quad \quad \exists \text{hasN}.\top \sqcap \text{NotN} \sqsubseteq \perp \}$$

$$37 \quad \mathcal{D} = \{ \text{VRBC} \sqsubset \exists \text{hasCM}.\top,$$

$$38 \quad \quad \text{VRBC} \sqsubset \exists \text{hasN}.\top,$$

$$39 \quad \quad \text{MRBC} \sqsubset \text{NotN} \}$$

40  
41  
42 Given a KB  $\mathcal{K} = \langle \mathcal{T}, \mathcal{D} \rangle$ , RC responds to some basic desiderata: the axioms in  $\mathcal{T}$   
43 and  $\mathcal{D}$  are included into the set of the derivable axioms, that moreover satisfy the  
44  
45  
46  
47  
48  
49  
50  
51  
52  
53  
54  
55  
56  
57  
58  
59  
60  
61  
62  
63  
64  
65

following properties.

$$\begin{array}{ll}
\text{(Ref)} & C \sqsubseteq C \\
\text{(LLE)} & \frac{\models C = D, C \sqsubseteq E}{D \sqsubseteq E} \\
\text{(And)} & \frac{C \sqsubseteq D, C \sqsubseteq E}{C \sqsubseteq D \sqcap E} \\
\text{(Or)} & \frac{C \sqsubseteq E, D \sqsubseteq E}{C \sqcup D \sqsubseteq E} \\
\text{(RW)} & \frac{C \sqsubseteq D, \models D \sqsubseteq E}{C \sqsubseteq E} \\
\text{(CM)} & \frac{C \sqsubseteq D, C \sqsubseteq E}{C \sqcap D \sqsubseteq E} \\
\text{(RM)} & \frac{C \sqsubseteq E, C \not\sqsubseteq \neg D}{C \sqcap D \sqsubseteq E}
\end{array}$$

Reflexivity (Ref), Left Logical Equivalence (LLE), Right Conjunction (And), Left Disjunction (Or), and Right Weakening (RW) are all properties that correspond to well-known properties of the classical subsumption relation  $\sqsubseteq$ . Cautious Monotonicity (CM) and Rational Monotonicity (RM) are constrained forms of Monotonicity that are useful and desirable in modelling defeasible reasoning. (CM) guarantees that our inferences are cumulative, that is, whatever we can conclude about typical  $C$ s (e.g. that they are in  $D$ ), we can add such information to  $C$  ( $C \sqcap D$ ) and still derive all the information associated to typical  $C$ s ( $C \sqcap D \sqsubseteq E$ ). The stronger principle (RM) is necessary to model the principle of *presumption of typicality*, that is, if the typical elements of a class  $C$  satisfy certain properties (e.g.  $E$ ) and we are not informed that a subclass  $C \sqcap D$  of  $C$  is atypical ( $C \not\sqsubseteq \neg D$ ), then we can assume that the typical elements of  $C \sqcap D$  satisfy all the properties characterising the typical elements of  $C$  ( $C \sqcap D \sqsubseteq E$ ). We refer to the work of Britz et al.[12] and Lehmann and Magidor [43] for a deeper explanation of the meaning of such properties and why they are desirable for modelling defeasible reasoning.

RC is a form of inferential closure that satisfies all the properties above; it is based on the semantic notion of ranked interpretation and on the directly connected notion of ranked entailment, which we illustrated next.

**Definition 1** (Ranked interpretation). *A ranked interpretation is a triple  $R = \langle \Delta^R, \cdot^R, \preceq^R \rangle$ , where  $\Delta^R$  and  $\cdot^R$  are as in the classical DL interpretations, while  $\preceq^R$  is a modular preference relation, that is, a preorder satisfying the following property:*

**Modularity:**  $\preceq^R$  is modular if and only if there is a ranking function  $rk : \Delta^R \rightarrow \mathbb{N}$  s.t. for every  $x, y \in \Delta^R$ ,  $x \preceq^R y$  iff  $rk(x) \leq rk(y)$ .<sup>2</sup>

---

<sup>2</sup>This definition of modularity is stronger than the classical one ([43], p.21), which states that “a

1  
2  
3  
4  
5  
6  
7  
8  
9  
10  
11  
12  
13  
14  
15  
16  
17  
18  
19  
20  
21  
22  
23  
24  
25  
26  
27  
28  
29  
30  
31  
32  
33  
34  
35  
36  
37  
38  
39  
40  
41  
42  
43  
44  
45  
46  
47  
48  
49  
50  
51  
52  
53  
54  
55  
56  
57  
58  
59  
60  
61  
62  
63  
64  
65

$a \preceq^R b$  means that the individual  $a$  is considered at least as typical as the individual  $b$ . Furthermore, a modular preorder allows to partition the domain  $\Delta^R$  of a ranked interpretation  $R$  into a sequence of *layers*,

$$\langle L_0^R, \dots, L_n^R, \dots \rangle,$$

where for every object  $x$ ,  $x \in L_0^R$  iff  $x \in \min_{\preceq^R}(\Delta^R)$  and  $x \in L_{i+1}^R$  iff  $x \in \min_{\preceq^R}(\Delta^R \setminus \bigcup_{0 \leq j \leq i} L_j^R)$ . From this partition, we can define the *height* of an individual  $a$  as

$$h_R(a) = i \text{ iff } a^R \in L_i^R.$$

The lower the height, the more typical is the individual in the interpretation. We can also think of a level of typicality for the concepts: the *height* of a concept in an interpretation  $R$  ( $h_R(C)$ ) as the lowest (most typical) layer in which the concept appears: i.e.

$$h_R(C) = i \text{ iff } \min_{\preceq^R}(C^R) \subseteq L_i^R.$$

**Definition 2** (Ranked model). *An interpretation  $R = \langle \Delta^R, \cdot^R, \preceq^R \rangle$  satisfies (is a model of)  $C \sqsubseteq D$  (denoted  $R \models C \sqsubseteq D$ ) iff  $C^R \subseteq D^R$ , and satisfies (is a model of)  $C \sqsubset D$  iff  $\min_{\preceq^R}(C^R) \subseteq D^R$  (denoted  $R \models C \sqsubset D$ ).  $R$  satisfies (is a model of)  $\mathcal{K} = \langle \mathcal{T}, \mathcal{D} \rangle$  iff  $R \models \alpha$  for all axioms  $\alpha \in \mathcal{T} \cup \mathcal{D}$ .*

Hence,  $C \sqsubset D$  is satisfied iff all the most typical individuals in  $C^R$  are also in  $D^R$ . We say that two ontologies are *ranked equivalent* iff they are satisfied by exactly the same ranked models, and that an ontology is *ranked consistent* iff there is at least a ranked model that satisfies it.

**Remark 1.** *Note that from the above definition of the satisfiability of an axiom  $C \sqsubset D$  we obtain the following correspondence: for every ranked model  $R$ ,*

$$R \models C \sqsubseteq \perp \text{ iff } R \models C \sqsubset \perp.$$

*This allows for the translation of every classical axiom  $C \sqsubseteq D$  into a defeasible axiom  $C \sqcap \neg D \sqsubset \perp$ . Note also that such a translation is not feasible in  $\mathcal{EL}^\perp$ , as  $\neg$  is not supported in  $\mathcal{EL}^\perp$ .*

---

preorder  $\preceq$  over a set  $\Delta$  is *modular* iff there is a totally ordered set  $\Omega$  (let  $\leq$  be the total preorder defined over  $\Omega$ ) and a function  $r : \Delta \mapsto \Omega$  s.t. for every  $a, b \in \Delta$ ,  $a \preceq b$  iff  $r(a) \leq r(b)$ ". Our definition of modularity implies that the order  $\preceq$  is well-founded, a property that is not implied by the original definition. While this difference is relevant to prove a representation result associating the class of the rational defeasible subsumption relations to the ranked interpretations, it is irrelevant for our purposes.

Now, the definition of ranked entailment follows directly from the notion of ranked model. So, let  $\mathfrak{R}^{\mathcal{K}}$  be the class of the ranked models of an ontology  $\mathcal{K}$ .

**Definition 3** (Ranked Entailment). *Given an ontology  $\mathcal{K} = \langle \mathcal{T}, \mathcal{D} \rangle$  and a defeasible axiom  $C \sqsubseteq D$ ,  $\mathcal{K}$  rationally entails  $C \sqsubseteq D$  (denoted  $\mathcal{K} \models_{\mathfrak{R}} C \sqsubseteq D$ ) iff  $\forall R \in \mathfrak{R}^{\mathcal{K}}$ ,  $R \models C \sqsubseteq D$ .*

Ranked entailment has a main drawback, since it is weak from the inferential point of view and does not satisfy the (RM) property [12, 43]. RC is a kind of entailment that extends Ranked Entailment, allowing to overcome such limitations, and we are going to define this notion as next. RC is based on a notion of *exceptionality* that is built on Ranked Entailment.

**Definition 4** (Exceptionality). *A concept  $C$  is exceptional w.r.t. an ontology  $\mathcal{K} = \langle \mathcal{T}, \mathcal{D} \rangle$  iff  $\mathcal{K} \models_{\mathfrak{R}} \top \sqsubseteq \neg C$ . That is to say,  $C$  is exceptional w.r.t.  $\mathcal{K}$  iff, for every model  $R \in \mathfrak{R}^{\mathcal{K}}$ ,*

$$C^R \cap \min_{\preceq^R}(\Delta^R) = \emptyset .$$

*An axiom  $C \sqsubseteq D$  is exceptional w.r.t.  $\mathcal{K}$  iff  $C$  is exceptional.*

Intuitively, a concept is exceptional w.r.t. an ontology iff it is not possible to have it satisfied by any typical individual (i.e., an individual in the layer 0, that corresponds to  $\min_{\preceq^R}(\Delta^R)$ ) in any ranked model of the ontology.

Iteratively applied, the notion of exceptionality allows to associate to every concept  $C$  a *rank value* w.r.t. an ontology  $\mathcal{K}$  in the following way.

1. A concept  $C$  has rank 0 ( $r_{\mathcal{K}}(C) = 0$ ) iff it is not exceptional w.r.t.  $\mathcal{K}$ , and we set  $r_{\mathcal{K}}(C \sqsubseteq D) = 0$  for every defeasible axiom having  $C$  as antecedent. The set of the axioms in  $\mathcal{D}$  with rank 0 is denoted as  $\mathcal{D}_0^r$ .
2. A concept  $C$  has rank 1 iff it does not have rank 0 and it is not exceptional w.r.t. the ontology  $\mathcal{K}^1$  composed by  $\mathcal{T}$  and the exceptional part of  $\mathcal{D}$ , that is  $\mathcal{K}^1 = \langle \mathcal{T}, \mathcal{D} \setminus \mathcal{D}_0^r \rangle$ . If  $r_{\mathcal{K}}(C) = 1$ , then we set  $r_{\mathcal{K}}(C \sqsubseteq D) = 1$ . The set of the axioms in  $\mathcal{D}$  with rank 1 is denoted as  $\mathcal{D}_1^r$ .
3. In general,  $C$  has rank  $i$  iff it does not have rank  $i - 1$  and it is not exceptional wrt  $\mathcal{K}^i = \langle \mathcal{T}, \mathcal{D} \setminus \bigcup_{j=0}^{i-1} \mathcal{D}_j^r \rangle$ . If  $r_{\mathcal{K}}(C) = i$ , then we set  $r_{\mathcal{K}}(C \sqsubseteq D) = i$ . The set of the axioms in  $\mathcal{D}$  with rank  $i$  is denoted  $\mathcal{D}_i^r$ .
4. By iterating the previous step, we eventually reach a (possibly empty) subset  $\mathcal{E} \subseteq \mathcal{D}$  s.t. all the axioms in  $\mathcal{E}$  are exceptional.<sup>3</sup> If  $\mathcal{E} \neq \emptyset$  we define the rank value of the axioms in  $\mathcal{E}$  as  $\infty$ , and the set  $\mathcal{E}$  is denoted  $\mathcal{D}_{\infty}^r$ .

---

<sup>3</sup>Since  $\mathcal{D}$  is finite, we must reach such a point.

As a consequence, according to the procedure above,  $\mathcal{D}$  can be partitioned into a sequence  $\langle \mathcal{D}_0^r, \dots, \mathcal{D}_n^r, \mathcal{D}_\infty^r \rangle$  ( $n \geq 0$ ), where  $\mathcal{D}_\infty^r$  may be possibly empty. The procedure allows to give a rank value to every concept and every defeasible subsumption. Using the rank values we can define the notion of RC as follows:

**Definition 5** (Rational Closure). *We say that  $C \sqsubseteq D$  is in the RC of an ontology  $\mathcal{K}$  iff*

$$r_{\mathcal{K}}(C \sqcap D) < r_{\mathcal{K}}(C \sqcap \neg D) \text{ or } r_{\mathcal{K}}(C) = \infty .$$

Informally, the above definition says that  $C \sqsubseteq D$  is in the rational closure of  $\mathcal{K}$  if the instances of  $C \sqcap D$  are more typical than the instances of  $C \sqcap \neg D$ .

### 3. Rational Closure in $\mathcal{EL}^\perp$

We now present a subsumption decision procedure under RC for  $\mathcal{EL}^\perp$ . To do so, we first introduce a semantic characterisation of RC, and then we build on that a decision procedure for  $\mathcal{EL}^\perp$ .

The translation of the characterisation of RC, as described in Section 2.2, into a procedure that is adequate for  $\mathcal{EL}^\perp$  is not immediate. This is due to two main problems. The first one is a theoretical problem, and the second one is a computational one.

Concerning the first issue, let us note that two main structural properties among those presented in Section 2.2, namely (OR) and (RM), cannot be properly expressed in the  $\mathcal{EL}^\perp$ . Therefore, a defeasible subsumption relation defined over  $\mathcal{EL}^\perp$  can at most satisfy the set of rules (REF)-(CM), that is, it can be characterised at most as a defeasible subsumption relation corresponding to a *cumulative* relation [40],<sup>4</sup> which, however, is acknowledged to be inferentially too weak—weaker than Ranked Entailment.

**Example 3.** *Related to Example 2, we have no piece of information forcing us to conclude that avian red blood cells represent an atypical subclass of vertebrate red blood cell, and so we would like to presume that they actually behave like typical vertebrate red blood cells. That means in the specific case that we should be able to derive that they have a nucleus and a cell membrane. This kind of conclusion, that is the simple inheritance of typical properties by subclasses that do not show any*

---

<sup>4</sup>So, we can define a notion of cumulative entailment in the ‘classical’ way. That is, we can decide the consequences of an ontology by taking under consideration all its cumulative models ([40], Section 3.5).

1  
2  
3  
4  
5  
6  
7 *kind of atypicality, is not derivable using cumulative or ranked entailment, while it*  
8 *is possible to derive them if we refer to RC.*  
9

10 This kind of reasoning is based on the *presumption of typicality* ([42], Section 3.1):  
11 that is, we always assume in our reasoning that we are in the most typical/expected  
12 situation that is conceivable, given the information at our disposal.

13 Even if we cannot express the presumption of typicality in  $\mathcal{EL}^\perp$  syntactically,  
14 by means of properties like (RM) defined over the defeasible subsumption relation,  
15 we can still characterise it semantically. This will allow us then to define also for  
16  $\mathcal{EL}^\perp$  the analogous version of RC: namely, an inference operation that preserves  
17 the presumption of typicality and allows to infer desirable conclusions by extending  
18 Ranked Entailment.  
19

20  
21 The second issue, the computational one, is about the computational complexity  
22 of our procedure. That is, we want also to define a procedure for Rational Closure in  
23  $\mathcal{EL}^\perp$  that preserves the polytime complexity of the classical (monotone) subsumption  
24 problem for  $\mathcal{EL}^\perp$ , which is not the case for the procedure proposed by Britz et al. [12].  
25  
26

### 27 3.1. Semantic Characterisation of RC for DLs

28 As seen in Section 2.2, entailment under RC can be decided using two ingredients:  
29

- 30 • the ranking function  $r$  based on the notion of ranked entailment.
- 31 • the decision rule stating that an axiom  $C \sqsubseteq D$  is derivable iff  $r(C \sqcap D) <$   
32  $r(C \sqcap \neg D)$ .

33 The second step, as it is, cannot be defined directly in  $\mathcal{EL}^\perp$  as concept complemen-  
34 tation is not supported. While we can formalise a conflict ( $C \sqcap D \sqsubseteq \perp$ ), we cannot  
35 express that two concepts are complementary. Moreover, the procedures for RC so  
36 far make use of negation and disjunction to compute the ranking function, and so  
37 they are not appropriate for  $\mathcal{EL}^\perp$  either.  
38

39 In order to define a procedure for Rational Closure in  $\mathcal{EL}^\perp$  that preserves the  
40 computational complexity of  $\mathcal{EL}^\perp$ , we have to bypass this expressivity problem. To  
41 do so, we proceed in the following way.  
42

- 43 1. We give a semantic characterisation of the RC of an ontology  $\mathcal{K}$ ;
- 44 2. We define a procedure that makes use only of the expressivity of  $\mathcal{EL}^\perp$  and is  
45 correct and complete w.r.t. the introduced semantic characterisation of RC.  
46

47 Concerning the first step, the semantical construction we are going to present is  
48 inspired by a semantical characterisation of RC for propositional logic by Booth and  
49 Paris [11]. Specifically, let  $\mathcal{K} = \langle \mathcal{T}, \mathcal{D} \rangle$  be a defeasible ontology, and let  $\mathfrak{R}^\mathcal{K}$  be the  
50  
51

class of the ranked models of  $\mathcal{K}$ ; also, let  $\Delta$  be a countable infinite domain, and  $\mathfrak{R}_\Delta^\mathcal{K}$  be the set of ranked models of  $\mathcal{K}$  that use  $\Delta$  as domain. The following proposition states that  $\mathfrak{R}_\Delta^\mathcal{K}$  is sufficient to define  $\models_{\mathfrak{R}}$ , i.e. we can rely on a single countable infinite domain  $\Delta$ .

**Proposition 1.** *For an ontology  $\mathcal{K} = \langle \mathcal{T}, \mathcal{D} \rangle$  and a defeasible axiom  $C \sqsubseteq D$ ,  $\mathcal{K} \models_{\mathfrak{R}} C \sqsubseteq D$  iff*

$$\forall R \in \mathfrak{R}_\Delta^\mathcal{K}, R \models C \sqsubseteq D .$$

Using the set  $\mathfrak{R}_\Delta^\mathcal{K}$ , if it is not empty, we define a new ranked model  $R_\mathcal{K}^\cup = \langle \Delta^{R_\mathcal{K}^\cup}, \cdot^{R_\mathcal{K}^\cup}, \prec^{R_\mathcal{K}^\cup} \rangle$  in the following way. Concerning the domain  $\Delta^{R_\mathcal{K}^\cup}$ , we consider in  $\Delta^{R_\mathcal{K}^\cup}$  one copy of  $\Delta$  for each model in  $\mathfrak{R}_\Delta^\mathcal{K}$ . Specifically, given  $\Delta = \{a, b, \dots\}$ , we indicate as  $\Delta_R = \{a_R, b_R, \dots\}$  a copy of the domain  $\Delta$  associated to an interpretation  $R \in \mathfrak{R}_\Delta^\mathcal{K}$  and define

$$\Delta^{R_\mathcal{K}^\cup} = \bigcup_{R \in \mathfrak{R}_\Delta^\mathcal{K}} \Delta_R .$$

Also the interpretation function and the preferential relation are defined referring directly to the models in  $\mathfrak{R}_\Delta^\mathcal{K}$ . That is, for every  $a_R, b_{R'} \in \Delta^{R_\mathcal{K}^\cup}$ ,

- $a_R \in A^{R_\mathcal{K}^\cup}$  iff  $a \in A^R$ , for every atomic concept  $A$ ;
- $\langle a_R, b_{R'} \rangle \in r^{R_\mathcal{K}^\cup}$  iff  $R = R'$  and  $\langle a, b \rangle \in r^R$ , for every role  $r$ ;
- $a_R \preceq^{R_\mathcal{K}^\cup} b_{R'}$  iff  $h_R(a) \leq h_{R'}(a)$ .

It is easy to prove by induction on the construction of the concepts that, for every  $a_R \in \Delta^{R_\mathcal{K}^\cup}$  and for every concept  $C$ ,  $a_R \in C^{R_\mathcal{K}^\cup}$  iff  $a \in C^R$ . Eventually, we can prove that  $R_\mathcal{K}^\cup$  is a ranked model characterising the Rational Closure of  $\mathcal{K}$ , as in Definition 5.

**Proposition 2.** *Let  $\mathcal{K}$  be an ontology having a ranked model. Then  $R_\mathcal{K}^\cup$  is a model of  $\mathcal{K}$  and for any pair of concepts  $C, D$ ,  $R_\mathcal{K}^\cup \models C \sqsubseteq D$  iff  $r_\mathcal{K}(C \sqcap D) < r_\mathcal{K}(C \sqcap \neg D)$  or  $r_\mathcal{K}(C) = \infty$ .*

An immediate consequence is the following result.

**Corollary 3.**  *$C \sqsubseteq D$  is in the RC of a KB  $\mathcal{K}$  iff  $R_\mathcal{K}^\cup \models C \sqsubseteq D$ .*

This concludes the first part.<sup>5</sup>

---

<sup>5</sup>An alternative semantic characterisation of RC for DLs has been given by Giordano et al. [36]. It can be shown that the two are equivalent.

---

**Procedure** Exceptional( $\mathcal{T}, \mathcal{E}$ )

---

**Input:**  $\mathcal{T}$  and  $\mathcal{E} \subseteq \mathcal{D}$

**Output:**  $\mathcal{E}' \subseteq \mathcal{E}$  such that  $\mathcal{E}'$  is the set of exceptional axioms w.r.t.  $\langle \mathcal{T}, \mathcal{E} \rangle$

1  $\mathcal{E}' := \emptyset$ ;

2  $\mathcal{T}_{\delta_{\mathcal{E}}} = \mathcal{T} \cup \{C \sqcap \delta_{\mathcal{E}} \sqsubseteq D \mid C \sqsupseteq D \in \mathcal{E}\}$ , where  $\delta_{\mathcal{E}}$  is a new atomic concept;

3 **foreach**  $C \sqsupseteq D \in \mathcal{E}$  **do**

4     **if**  $\mathcal{T}_{\delta_{\mathcal{E}}} \models C \sqcap \delta_{\mathcal{E}} \sqsubseteq \perp$  **then**

5          $\mathcal{E}' := \mathcal{E}' \cup \{C \sqsupseteq D\}$ ;

6 **return**  $\mathcal{E}'$

---

### 3.2. Subsumption Decision Procedure for $\mathcal{EL}^{\perp}$ under RC

Now we are going to introduce a decision procedure for RC. Unlike the algorithm in [12], this method neither uses negation nor disjunction and is directly applicable to  $\mathcal{EL}^{\perp}$ .

Specifically, consider a defeasible  $\mathcal{EL}^{\perp}$  ontology  $\mathcal{K} = \langle \mathcal{T}, \mathcal{D} \rangle$  with  $\mathcal{T} = \{E_1 \sqsubseteq F_1, \dots, E_m \sqsubseteq F_m\}$  and  $\mathcal{D} = \{C_1 \sqsupseteq D_1, \dots, C_n \sqsupseteq D_n\}$ . We will define two procedures: the first one is a *ranking* procedure, that transforms the initial ontology  $\mathcal{K} = \langle \mathcal{T}, \mathcal{D} \rangle$  into a ranked equivalent ontology  $\mathcal{K}^* = \langle \mathcal{T}^*, \mathcal{D}^* \rangle$ , where  $\mathcal{D}^*$  is partitioned into a sequence  $\mathcal{D}_0, \dots, \mathcal{D}_n$ , with each  $\mathcal{D}_i$  containing the defeasible axioms with rank  $i$ ; the second one uses  $\mathcal{K}^*$  to decide whether an axiom  $C \sqsupseteq D$  is in the RC of  $\mathcal{K}$ .

#### 3.2.1. The Ranking Procedure

Given an ontology  $\langle \mathcal{T}, \mathcal{D} \rangle$ , the ranking procedure is defined by means of two procedures: one for finding exceptional axioms and one for determining the rank value of axioms, as defined in Section 2.2.

In the following, given an ontology  $\langle \mathcal{T}, \mathcal{E} \rangle$ , and a new atomic concept  $\delta_{\mathcal{E}}$ , we define  $\mathcal{T}_{\delta_{\mathcal{E}}}$  as

$$\mathcal{T}_{\delta_{\mathcal{E}}} = \mathcal{T} \cup \{C \sqcap \delta_{\mathcal{E}} \sqsubseteq D \mid C \sqsupseteq D \in \mathcal{E}\}. \quad (1)$$

**Find exceptional axioms:** given an ontology  $\langle \mathcal{T}, \mathcal{E} \rangle$ , the first step is to compute the exceptional axioms  $C \sqsupseteq D$  in  $\mathcal{E}$ . To do so, given  $\mathcal{T}_{\delta_{\mathcal{E}}}$  we check if

$$\mathcal{T}_{\delta_{\mathcal{E}}} \models C \sqcap \delta_{\mathcal{E}} \sqsubseteq \perp.$$

**Remark 2.** *Informally, we introduce the atom  $\delta$  as a way of representing the information that characterises the lowest rank. Hence, its introduction is aimed at the formalisation in the classical framework of the typicality of the lowest layer:  $C \sqcap \delta$  is introduced to represent the individuals falling under  $C$  and lying in the lowest layer.*

We can prove that this procedure is correct w.r.t. the exceptionality step of the RC characterisation given in Section 2.2 (see Definition 4).

**Proposition 4.** *For an ontology  $\mathcal{K} = \langle \mathcal{T}, \mathcal{E} \rangle$  and  $C \sqsubseteq D \in \mathcal{E}$ , if  $\mathcal{T}_{\delta_{\mathcal{E}}} \models C \sqcap \delta_{\mathcal{E}} \sqsubseteq \perp$  then for every model  $R \in \mathfrak{R}^{\mathcal{K}}$ ,  $C^R \cap \min_{\prec R}(\Delta^R) = \emptyset$ .*

Hence, the set  $\mathcal{E}' = \{C \sqsubseteq D \in \mathcal{E} \mid \mathcal{T}_{\delta_{\mathcal{E}}} \models C \sqcap \delta_{\mathcal{E}} \sqsubseteq \perp\}$  contains only defeasible axioms that are exceptional w.r.t.  $\langle \mathcal{T}, \mathcal{E} \rangle$ . The simple algorithm `Exceptional`( $\mathcal{T}, \mathcal{E}$ ) illustrates how to compute the exceptional axioms.

**Find rank value of the axioms:** now we use algorithm `Exceptional` to define a procedure to find the rank value of axioms in  $\mathcal{D}$ .

Algorithm `ComputeRanking`( $\mathcal{K}$ ) illustrates how we do it, which we comment on next.

We start considering an ontology  $\mathcal{K} = \langle \mathcal{T}, \mathcal{D} \rangle$ . Lines 8-10 loop until we reach a (possibly empty) fixed-point of exceptional axioms.

**Remark 3.** *Since the set  $\mathcal{D}$  is finite and at every step of the exceptionality procedure  $\mathcal{E}_{i+1} \subseteq \mathcal{E}_i$  holds, we will necessarily reach a fixed point, that is,  $\mathcal{E}_{i+1} = \mathcal{E}_i$  for some  $i$ .*

We can prove that this procedure is correct w.r.t. the infinite rank of the RC procedure, that is, that all the defeasible axioms that are in the fixed point are axioms that have infinite rank value in the RC (see Section 2.2, Step 4).

**Corollary 5.** *If a defeasible axiom  $C \sqsubseteq D$  is in the fixed point of the exceptionality procedure, i.e. at some step of the algorithm `ComputeRanking`,  $C \sqsubseteq D \in \mathcal{D}_{\infty}$ ,<sup>6</sup> then  $C \sqsubseteq D \in \mathcal{D}_{\infty}^r$ .*

Hence, each axiom  $C \sqsubseteq D$  in the fixed point of the exceptionality function is eliminated from  $\mathcal{D}^*$  (line 12) and we add  $C \sqsubseteq \perp$  to  $\mathcal{T}^*$  (line 13). We repeat the loop in lines 5 - 13 until no exceptional axioms can be found anymore (i.e.,  $\mathcal{E}_i = \mathcal{E}_{i+1} = \emptyset$ , for some  $i \geq 0$ ).

---

<sup>6</sup>Line 11 of algorithm `ComputeRanking`.

---

**Procedure** ComputeRanking( $\mathcal{K}$ )

---

**Input:** Ontology  $\mathcal{K} = \langle \mathcal{T}, \mathcal{D} \rangle$ 
**Output:** Ontology  $\langle \mathcal{T}^*, \mathcal{D}^* \rangle$  and the partitioning (ranking)  $\mathfrak{R} = \{\mathcal{D}_0, \dots, \mathcal{D}_n\}$   
for  $\mathcal{D}^*$ 

```

1   $\mathcal{T}^* := \mathcal{T}$ ;
2   $\mathcal{D}^* := \mathcal{D}$ ;
3   $\mathfrak{R} := \emptyset$ ;
4  repeat
5     $i := 0$ ;
6     $\mathcal{E}_0 := \mathcal{D}^*$ ;
7     $\mathcal{E}_1 := \text{Exceptional}(\mathcal{T}^*, \mathcal{E}_0)$ ;
8    while  $\mathcal{E}_{i+1} \neq \mathcal{E}_i$  do
9       $i := i + 1$ ;
10      $\mathcal{E}_{i+1} := \text{Exceptional}(\mathcal{T}^*, \mathcal{E}_i)$ ;
11      $\mathcal{D}_\infty := \mathcal{E}_i$ ;
12      $\mathcal{D}^* := \mathcal{D}^* \setminus \mathcal{D}_\infty$ ;
13      $\mathcal{T}^* := \mathcal{T}^* \cup \{C \sqsubseteq \perp \mid C \sqsupseteq D \in \mathcal{D}_\infty\}$ ;
14 until  $\mathcal{D}_\infty = \emptyset$ ;
15 for  $j = 1$  to  $i$  do
16    $\mathcal{D}_{j-1} := \mathcal{E}_{j-1} \setminus \mathcal{E}_j$ ;
17    $\mathfrak{R} := \mathfrak{R} \cup \{\mathcal{D}_{j-1}\}$ ;
18 return  $\langle \mathcal{T}^*, \mathcal{D}^* \rangle, \mathfrak{R}$ 

```

---

**Remark 4.** Note that the loop in between lines 5 - 13 allows us to move all the strict knowledge possibly ‘hidden’ inside the DBox to the TBox. That is, there may be defeasible axioms in the DBox that are actually equivalent to classical axioms, and, thus, can be moved from the DBox to the TBox as classical inclusion axioms. Example 4 illustrates such a case.

Lines 15-17 determine the rank value of the remaining defeasible axioms not in  $\mathcal{D}_\infty$ . That is, set  $\mathcal{D}_{j-1}$  is the set of axioms of rank  $j - 1$  ( $1 \leq j \leq i$ ) and are those axioms in  $\mathcal{E}_{j-1} \setminus \mathcal{E}_j$ .

Indeed, we can prove now that the algorithm **ComputeRanking** correctly computes the rank value of the axioms in  $\mathcal{D}$ . To do so, first we prove that the transformation of a KB  $\langle \mathcal{T}, \mathcal{D} \rangle$  into  $\langle \mathcal{T}^*, \mathcal{D}^* \rangle$  does not affect the rational closure.

**Proposition 6.** *The ontology  $\langle \mathcal{T}^*, \mathcal{D}^* \rangle$  is ranked equivalent to the ontology  $\langle \mathcal{T}, \mathcal{D} \rangle$ .*

The fact that  $\langle \mathcal{T}, \mathcal{D} \rangle$  and  $\langle \mathcal{T}^*, \mathcal{D}^* \rangle$  are ranked equivalent means that (if  $\langle \mathcal{T}, \mathcal{D} \rangle$  is ranked consistent), for a fixed domain  $\Delta$ , they have exactly the same model  $R_{\mathcal{K}}^{\cup}$ . From this fact and Proposition 2 we can immediately conclude that the RCs of the two KBs are equivalent. That is,

**Proposition 7.** *For every pair of concepts  $C, D$ ,  $C \sqsubseteq D$  is in the RC of  $\langle \mathcal{T}, \mathcal{D} \rangle$  iff it is in the RC of  $\langle \mathcal{T}^*, \mathcal{D}^* \rangle$ .*

**Remark 5.** *As our semantic characterisation of RC and Proposition 7 indicate, RC is a form of closure that is not affected by the syntactic form of the axioms in the ontology, that is, given two ontologies that are equivalent from the semantic point of view, their RC is the same.*

Now we can prove that, once we have transformed the ontology  $\langle \mathcal{T}, \mathcal{D} \rangle$  into the equivalent ontology  $\langle \mathcal{T}^*, \mathcal{D}^* \rangle$ , the exceptionality function is also complete w.r.t. the ranking procedure of RC. That is,

**Proposition 8.** *Let  $\mathcal{K} = \langle \mathcal{T}, \mathcal{D} \rangle$  be an ontology base s.t.  $\mathcal{D}_{\infty} = \emptyset$ . For  $C \sqsubseteq D \in \mathcal{D}$ , if  $C^R \cap \min_{\prec_R} \Delta^R = \emptyset$  for every model  $R \in \mathfrak{R}^{\mathcal{K}}$ , then  $\mathcal{T}_{\delta_{\mathcal{D}}} \models C \sqcap \delta_{\mathcal{D}} \sqsubseteq \perp$ .*

The main proposition now is a direct consequence of Propositions 4 and 8.

**Proposition 9.** *Given an ontology  $\mathcal{K} = \langle \mathcal{T}, \mathcal{D} \rangle$ , consider the sets  $\mathcal{T}^*, \mathcal{D}_0, \dots, \mathcal{D}_n$  as determined by `ComputeRanking`( $\mathcal{K}$ ). Then for every defeasible axiom  $C \sqsubseteq D \in \mathcal{D}$ ,  $r_{\mathcal{K}}(C \sqsubseteq D) = i$  ( $0 \leq i \leq n$ ) iff  $C \sqsubseteq D$  is in  $\mathcal{D}_i$ , and  $r_{\mathcal{K}}(C \sqsubseteq D) = \infty$  iff  $C \sqsubseteq \perp \in \mathcal{T}^*$ .*

This completes the description of the axiom ranking procedure.

Next we describe some examples that illustrate the behaviour of the ranking procedure. The following example shows a case in which there is non-defeasible knowledge ‘hidden’ in a DBox and that more than one cycle of the lines 4-14 in Algorithm `ComputeRanking` is needed to extract this information.

1  
2  
3  
4  
5  
6  
7 **Example 4.** Let  $\mathcal{K} = \langle \mathcal{T}, \mathcal{D} \rangle$  be an ontology with

$$\begin{aligned} \mathcal{T} &= \{ A \sqsubseteq B, \\ &\quad B \sqcap D \sqsubseteq \perp \} \\ \mathcal{D} &= \{ B \sqsubseteq C, \\ &\quad A \sqsubseteq D, \\ &\quad E \sqsubseteq \exists r.A \} . \end{aligned}$$

8  
9  
10  
11  
12  
13  
14  
15  
16  
17 It can be verified that the execution of `ComputeRanking`( $\mathcal{K}$ ) is as follows:

$$\begin{aligned} &\mathcal{T}^* = \mathcal{T}, \mathcal{D}^* = \mathcal{D}, \mathfrak{R} = \emptyset \\ \text{repeat1 } &i = 0 \quad \mathcal{E}_0 = \mathcal{D}^*, \mathcal{E}_1 = \{A \sqsubseteq D\} \\ &i = 1 \quad \mathcal{E}_2 = \{A \sqsubseteq D\} \text{ (end while)} \\ &\mathcal{D}_\infty = \mathcal{E}_2 = \{A \sqsubseteq D\} \\ &\mathcal{D}^* = \mathcal{D}^* \setminus \{A \sqsubseteq D\} = \{B \sqsubseteq C, E \sqsubseteq \exists r.A\} \\ &\mathcal{T}^* = \mathcal{T}^* \cup \{A \sqsubseteq \perp\} = \{A \sqsubseteq B, B \sqcap D \sqsubseteq \perp, A \sqsubseteq \perp\} \\ \\ \text{repeat2 } &i = 0 \quad \mathcal{E}_0 = \mathcal{D}^*, \mathcal{E}_1 = \{E \sqsubseteq \exists r.A\} \\ &i = 1 \quad \mathcal{E}_2 = \{E \sqsubseteq \exists r.A\} \text{ (end while)} \\ &\mathcal{D}_\infty = \mathcal{E}_2 = \{E \sqsubseteq \exists r.A\} \\ &\mathcal{D}^* = \mathcal{D}^* \setminus \{E \sqsubseteq \exists r.A\} = \{B \sqsubseteq C\} \\ &\mathcal{T}^* = \mathcal{T}^* \cup \{E \sqsubseteq \perp\} = \{A \sqsubseteq B, B \sqcap D \sqsubseteq \perp, A \sqsubseteq \perp, E \sqsubseteq \perp\} \\ \\ \text{repeat3 } &i = 0 \quad \mathcal{E}_0 = \mathcal{D}^*, \mathcal{E}_1 = \emptyset \\ &i = 1 \quad \mathcal{E}_2 = \emptyset \text{ (end while)} \\ &\mathcal{D}_\infty = \mathcal{E}_2 \\ &\mathcal{D}^* = \mathcal{D}^* \setminus \emptyset = \{B \sqsubseteq C\} \\ &\mathcal{T}^* = \mathcal{T}^* \cup \emptyset = \{A \sqsubseteq B, B \sqcap D \sqsubseteq \perp, A \sqsubseteq \perp, E \sqsubseteq \perp\} \text{ (end repeat)} \\ \\ \text{for } &j = 1 \quad \mathcal{D}_0 = \mathcal{E}_0 \setminus \mathcal{E}_1 = \{B \sqsubseteq C\} \\ &\mathfrak{R} = \mathfrak{R} \cup \{\mathcal{D}_0\} = \{\mathcal{D}_0\} \text{ (end for)} \end{aligned}$$

Therefore,  $\text{ComputeRanking}(\mathcal{K})$  terminates with

$$\begin{aligned}\mathcal{T}^* &= \{ A \sqsubseteq B, B \sqcap D \sqsubseteq \perp, A \sqsubseteq \perp, E \sqsubseteq \perp \} \\ \mathcal{D}^* &= \{ B \sqsubseteq C \} \\ \mathfrak{R} &= \{ \mathcal{D}_0 \} \\ \mathcal{D}_0 &= \{ B \sqsubseteq C \}.\end{aligned}$$

The only defeasible axiom in  $\mathcal{D}^*$  is  $B \sqsubseteq C$ , which has rank 0. Axioms  $A \sqsubseteq D$  and  $E \sqsubseteq \exists r.A$  have rank  $\infty$  instead, and so are substituted by the classical axioms  $A \sqsubseteq \perp$  and  $E \sqsubseteq \perp$ .

**Example 5.** Consider the ontology  $\mathcal{K}$  in Example 2. It can be verified that the execution of  $\text{ComputeRanking}(\mathcal{K})$  is as follows:

$$\begin{aligned}\mathcal{T}^* &= \mathcal{T}, \mathcal{D}^* = \mathcal{D}, \mathfrak{R} = \emptyset \\ \text{repeat } i &= 0 \quad \mathcal{E}_0 = \mathcal{D}^*, \mathcal{E}_1 = \{\text{MRBC} \sqsubseteq \text{NotN}\} \\ i &= 1 \quad \mathcal{E}_2 = \emptyset \\ i &= 2 \quad \mathcal{E}_3 = \emptyset \text{ (end while)} \\ \mathcal{D}_\infty &= \mathcal{E}_3 = \emptyset \\ \mathcal{D}^* &= \mathcal{D}^* \setminus \emptyset = \mathcal{D} \\ \mathcal{T}^* &= \mathcal{T}^* \cup \emptyset = \mathcal{T} \text{ (end repeat)} \\ \text{for } j &= 1 \quad \mathcal{D}_0 = \mathcal{E}_0 \setminus \mathcal{E}_1 = \{\text{VRBC} \sqsubseteq \exists \text{hasCM.T}, \text{VRBC} \sqsubseteq \exists \text{hasN.T}\} \\ \mathfrak{R} &= \mathfrak{R} \cup \{\mathcal{D}_0\} = \{\mathcal{D}_0\} \\ j &= 2 \quad \mathcal{D}_1 = \mathcal{E}_1 \setminus \mathcal{E}_2 = \{\text{MRBC} \sqsubseteq \text{NotN}\} \\ \mathfrak{R} &= \mathfrak{R} \cup \{\mathcal{D}_1\} = \{\mathcal{D}_0, \mathcal{D}_1\} \text{ (end for)}\end{aligned}$$

Therefore,  $\text{ComputeRanking}(\mathcal{K})$  terminates with

$$\begin{aligned}\mathcal{T}^* &= \{ \text{CRBC} \sqsubseteq \text{MRBC}, \text{ARBC} \sqsubseteq \text{VRBC}, \text{MRBC} \sqsubseteq \text{VRBC}, \exists \text{hasN.T} \sqcap \text{NotN} \sqsubseteq \perp \} \\ \mathcal{D}^* &= \{ \text{VRBC} \sqsubseteq \exists \text{hasCM.T}, \text{VRBC} \sqsubseteq \exists \text{hasN.T}, \text{MRBC} \sqsubseteq \text{NotN} \} \\ \mathfrak{R} &= \{ \mathcal{D}_0, \mathcal{D}_1 \} \\ \mathcal{D}_0 &= \{ \text{VRBC} \sqsubseteq \exists \text{hasCM.T}, \text{VRBC} \sqsubseteq \exists \text{hasN.T} \} \\ \mathcal{D}_1 &= \{ \text{MRBC} \sqsubseteq \text{NotN} \}.\end{aligned}$$

Defeasible axioms in  $\mathcal{D}_0$  have rank value 0, while the axiom in  $\mathcal{D}_1$  has rank value 1.

So far, we have defined an algorithm that determines the rank value of the axioms in a KB, which is based on a sequence of classical  $\mathcal{EL}^\perp$  subsumption decision steps (those in the `Exceptional` algorithm, line 4.).

### 3.2.2. A Decision Procedure for Rational Closure

Now, we provide an algorithm to decide whether a defeasible axiom  $C \sqsubseteq D$  is in the RC of an  $\mathcal{EL}^\perp$  KB. So, given a KB  $\mathcal{K}$ , let us assume that we have applied to it the `ComputeRanking` algorithm and, thus, the returned KB does not have defeasible inclusion axioms with  $\infty$  as rank value.

In the following, given  $\mathcal{K} = \langle \mathcal{T}, \mathcal{D} \rangle$  as the output of the `ComputeRanking` algorithm, with  $\mathcal{D}$  partitioned into  $\mathcal{D}_0, \dots, \mathcal{D}_n$ , and given new atomic concepts  $\delta_i$  ( $0 \leq i \leq n$ ), we define  $\mathcal{T}_{\delta_i}$  as

$$\mathcal{T}_{\delta_i} = \mathcal{T} \cup \{C \sqcap \delta_i \sqsubseteq D \mid C \sqsubseteq D \in \bigcup_{i \leq j \leq n} \mathcal{D}_j\}. \quad (2)$$

**Example 6** (Example 5 cont.). *From  $\langle \langle \mathcal{T}^*, \mathcal{D}^* \rangle, \mathfrak{R} \rangle$  in Example 5, we get by definition that*

$$\begin{aligned} \mathcal{T}_{\delta_0}^* = \mathcal{T}^* \cup \{ & \text{VRBC} \sqcap \delta_0 \sqsubseteq \exists \text{hasCM}.\top, \\ & \text{VRBC} \sqcap \delta_0 \sqsubseteq \exists \text{hasN}.\top, \\ & \text{MRBC} \sqcap \delta_0 \sqsubseteq \text{NotN} \}. \end{aligned}$$

and

$$\mathcal{T}_{\delta_1}^* = \mathcal{T}^* \cup \{\text{MRBC} \sqcap \delta_1 \sqsubseteq \text{NotN}\}.$$

Note that we get the following results:

$$\begin{aligned} \mathcal{T}_{\delta_0}^* & \models \text{MRBC} \sqcap \delta_0 \sqsubseteq \perp \\ \mathcal{T}_{\delta_0}^* & \not\models \text{VRBC} \sqcap \delta_0 \sqsubseteq \perp \\ \mathcal{T}_{\delta_1}^* & \not\models \text{MRBC} \sqcap \delta_1 \sqsubseteq \perp \end{aligned}$$

We define now an inference relation  $\vdash_{rc}$ , and then we prove that it corresponds to the RC. The decision procedure is the following.

**Definition 6** (Inference relation  $\vdash_{rc}$ ). *Let  $\mathcal{K} = \langle \mathcal{T}, \mathcal{D} \rangle$  be the output of the algorithm `ComputeRanking`, with  $\mathcal{D}$  partitioned into  $\mathcal{D}_0, \dots, \mathcal{D}_n$ , and consider a defeasible subsumption axiom  $C \sqsubseteq D$ . Let  $i$  (if it exists) be the lowest integer s.t.  $0 \leq i \leq n$  and*

$$\mathcal{T}_{\delta_i} \not\models C \sqcap \delta_i \sqsubseteq \perp.$$

If such an  $i$  exists, let

$$\mathcal{K} \vdash_{rc} C \sqsubseteq D \text{ iff } \mathcal{T}_{\delta_i} \models C \sqcap \delta_i \sqsubseteq D.$$

If there is not such an  $i$ , let

$$\mathcal{K} \vdash_{rc} C \sqsubseteq D \text{ iff } \mathcal{T} \models C \sqsubseteq D.$$

---

**Procedure RationalClosure( $\mathcal{K}, \alpha$ )**

---

**Input:** Ontology  $\mathcal{K}$  and defeasible axiom  $\alpha$  of the form  $C \sqsubseteq D$

**Output:** true iff  $C \sqsubseteq D$  is in the Rational Closure of  $\mathcal{K}$

```

1   $CL := \mathcal{T} \models C \sqsubseteq D$  //Check if  $\alpha$  holds classically;
2  if  $CL$  then
3    return  $CL$ 
4   $\langle \langle \mathcal{T}^*, \mathcal{D}^* \rangle, \{\mathcal{D}_0, \dots, \mathcal{D}_n\} \rangle := \text{ComputeRanking}(\mathcal{K})$ ;
5   $CL := \mathcal{T}^* \models C \sqsubseteq D$  //Check if  $\alpha$  holds classically, after finding strict
6  knowledge in  $\mathcal{D}$ ;
7  if  $CL$  then
8    return  $CL$ 
9  //Compute  $C$ 's rank  $i$ ;
10  $i := 0$ ;  $\mathcal{D}_{\mathfrak{R}} := \mathcal{D}^*$ ;
11  $\mathcal{T}_{\delta_0} := \mathcal{T}^* \cup \{E \sqcap \delta_0 \sqsubseteq F \mid E \sqsubseteq F \in \mathcal{D}_{\mathfrak{R}}\}$ , where  $\delta_0$  is a new atomic concept;
12 while  $\mathcal{T}_{\delta_i} \models C \sqcap \delta_i \sqsubseteq \perp$  and  $\mathcal{D}_{\mathfrak{R}} \neq \emptyset$  do
13    $\mathcal{D}_{\mathfrak{R}} := \mathcal{D}_{\mathfrak{R}} \setminus \mathcal{D}_i$ ;  $i := i + 1$ ;
14    $\mathcal{T}_{\delta_i} := \mathcal{T}^* \cup \{E \sqcap \delta_i \sqsubseteq F \mid E \sqsubseteq F \in \mathcal{D}_{\mathfrak{R}}\}$ , where  $\delta_i$  is a new atomic concept;
15 // Check now if  $\alpha$  holds under RC;
16 if  $\mathcal{T}_{\delta_i} \not\models C \sqcap \delta_i \sqsubseteq \perp$  then
17   return  $\mathcal{T}_{\delta_i} \models C \sqcap \delta_i \sqsubseteq D$ 
18 else
19   return  $CL$ 

```

---

The first point determines the rank of the concept  $C$  (i.e., the lowest  $i$  s.t.  $\mathcal{T}_{\delta_i} \not\models C \sqcap \delta_i \sqsubseteq \perp$ ), while the second one establishes whether all the most typical individuals in  $C$  (the ones in Layer  $i$ ) fall also under the concept  $D$  (i.e.,  $\mathcal{T}_{\delta_i} \models C \sqcap \delta_i \sqsubseteq D$ ). If such an  $i$  does not exist, we cannot associate to  $C$  any of the defeasible information in  $\mathcal{D}$ , hence  $\mathcal{K} \vdash_{rc} C \sqsubseteq D$  iff  $\mathcal{T} \models C \sqsubseteq D$ .

Prodecure **RationalClosure** illustrates how to decide defeasible entailment under RC.

**Example 7** (Example 6 cont.). *We want to decide whether the red blood cells of a cow (CRBC) should presumably have a nucleus, that is, whether  $\text{CRBC} \sqsubseteq \exists \text{hasN.T}$ ,  $\text{CRBC} \sqsubseteq \text{notN}$ , or neither of them are in the RC of  $\mathcal{K}$ .*

*First of all we check which is the rank of CRBC, then to check whether we can conclude that the typical elements of CRBC are in  $\text{hasN.T}$  (or in  $\text{notN}$ ). We have*

1  
2  
3  
4  
5  
6  
7 that

$$\begin{aligned} \mathcal{T}_{\delta_0}^* &\models \text{CRBC} \sqcap \delta_0 \sqsubseteq \perp \\ \mathcal{T}_{\delta_1}^* &\not\models \text{CRBC} \sqcap \delta_1 \sqsubseteq \perp . \end{aligned}$$

8  
9  
10 Hence CRBC is of rank 1, and we can associate to it the defeasible information of  
11 rank 1, that is, we can use the TBox  $\mathcal{T}_{\delta_1}^*$ .  
12  
13  
14

$$\begin{aligned} \mathcal{T}_{\delta_1}^* &\not\models \text{CRBC} \sqcap \delta_1 \sqsubseteq \exists \text{hasN} . \top \\ \mathcal{T}_{\delta_1}^* &\models \text{CRBC} \sqcap \delta_1 \sqsubseteq \text{notN} . \end{aligned}$$

15  
16  
17 Therefore, we conclude that it's not the case that the red blood cells of cows presumably  
18 have a nucleus. That is,  $\text{RationalClosure}(\mathcal{K}, \text{CRBC} \sqsubseteq \exists \text{hasN} . \top)$  and  
19  $\text{RationalClosure}(\mathcal{K}, \text{CRBC} \sqsubseteq \text{notN})$  return respectively false and true.  
20  
21  
22  
23  
24

25 The following proposition shows that the inference relation  $\vdash_{rc}$  is correct and com-  
26 plete w.r.t. RC, in particular w.r.t. the semantic characterisation of RC we have given  
27 in Section 3.1.  
28

29 **Theorem 10.** Given a KB  $\mathcal{K} = \langle \mathcal{T}, \mathcal{D} \rangle$ , its characteristic RC-model  $R_{\mathcal{K}}^{\cup}$ , and a  
30 defeasible subsumption axiom  $C \sqsubseteq D$ . Then,  
31

$$\mathcal{K} \vdash_{rc} C \sqsubseteq D \text{ iff } R_{\mathcal{K}}^{\cup} \models C \sqsubseteq D .$$

32  
33  
34 Furthermore, as we have moved into  $\mathcal{T}^*$  all the classical information possibly 'hidden'  
35 in  $\mathcal{D}$ , the strict information in the RC of  $\langle \mathcal{T}, \mathcal{D} \rangle$  can be derived from  $\mathcal{T}^*$  alone. That  
36 is:  
37  
38

39 **Proposition 11.**  $C \sqsubseteq D$  is in the rational closure of  $\langle \mathcal{T}, \mathcal{D} \rangle$  iff  $\mathcal{T}^* \models C \sqsubseteq D$ .  
40

41 From Proposition 11 we also obtain immediately a consistency test for a KB  $\mathcal{K} =$   
42  $\langle \mathcal{T}, \mathcal{D} \rangle$ .  
43

44 **Corollary 12.** An ontology  $\mathcal{K} = \langle \mathcal{T}, \mathcal{D} \rangle$  is ranked inconsistent iff  $\mathcal{T}^* \models \top \sqsubseteq \perp$ .  
45  
46

### 47 3.3. Normal Form.

48 Usually, a classical  $\mathcal{EL}^{\perp}$  ontology is transformed into a normal form to which one  
49 then applies a subsumption decision procedure (see, e.g. [2]). In the following, we  
50 extend the notion of normal form to defeasible  $\mathcal{EL}^{\perp}$  ontologies, and show that our  
51 subsumption decision procedure works fine for normalised ontologies as well.  
52

53 So, let us recap that an  $\mathcal{EL}^{\perp}$  ontology is in *normal form* if the axioms in it have  
54 the form:  
55  
56

- $C_1 \sqsubseteq D$
- $C_1 \sqcap C_2 \sqsubseteq D$
- $\exists R.C_1 \sqsubseteq D$
- $C_1 \sqsubseteq \exists R.C_2$

where  $C_1, C_2 \in \mathbf{N}_{\mathcal{E}} \cup \{\top\}$  and  $D \in \mathbf{N}_{\mathcal{E}} \cup \{\top, \perp\}$ . One may transform axioms in normal form by applying the following rules:

- R1  $C \sqcap \hat{D} \sqsubseteq E \mapsto \hat{D} \sqsubseteq A, C \sqcap A \sqsubseteq E$ ;
- R2  $\exists R.\hat{C} \sqsubseteq D \mapsto \hat{C} \sqsubseteq A, \exists R.A \sqsubseteq D$ ;
- R3  $\perp \sqsubseteq D \mapsto \emptyset$ .
- R4  $\hat{C} \sqsubseteq \hat{D} \mapsto \hat{C} \sqsubseteq A, A \sqsubseteq \hat{D}$ ;
- R5  $B \sqsubseteq \exists R.\hat{C} \mapsto B \sqsubseteq \exists R.A, A \sqsubseteq \hat{C}$ ;
- R6  $B \sqsubseteq C \sqcap D \mapsto B \sqsubseteq C, B \sqsubseteq D$ ,

where  $\hat{C}, \hat{D} \notin \mathbf{N}_{\mathcal{E}} \cup \{\top\}$ , and  $A$  is a new atomic concept. Rules R1-R3 are applied first, then rules R4-R6 are applied, until no more rule can be applied. It is easily verified that the transformation is time polynomial and entailment preserving, i.e., given a TBox  $\mathcal{T}$  and its normal form transformation  $\mathcal{T}'$ , then  $\mathcal{T} \models C \sqsubseteq D$  iff  $\mathcal{T}' \models C \sqsubseteq D$  for every  $C, D$ .

The above result is not sufficient to guarantee that we can apply this kind of transformation also to defeasible KBs. The problem is that the notion of *logical equivalence* in a preferential setting, or *rational equivalence* as we have called it up to now, follows rules that are slightly different from the ones characterising logical equivalence in classical reasoning. In particular, we are allowed to substitute a concept with a logically equivalent one on the left of a defeasible subsumption relation (LLE allows it) and on the right (a consequence of RW). However, there are cases of expressions that are equivalent in their classical formulation but not equivalent in the preferential one. For example, the two axioms  $C \sqsubseteq D$  and  $\top \sqsubseteq \neg C \sqcup D$  are equivalent, while  $C \sqsubseteq\!\!\sqsubseteq D$  and  $\top \sqsubseteq\!\!\sqsubseteq \neg C \sqcup D$  are not ranked equivalent. Therefore, the normal form transformation rules have to be designed in way to preserve rational equivalence.

So, let  $\mathcal{K} = \langle \mathcal{T}, \mathcal{D} \rangle$  be an ontology. We say that  $\mathcal{D}$  is in *normal form* if each defeasible axiom in  $\mathcal{D}$  is of the form  $A \sqsubseteq\!\!\sqsubseteq B$ , where  $A, B \in \mathbf{N}_{\mathcal{E}}$ . We say that  $\mathcal{K}$  is

in *normal form* if  $\mathcal{T}$  and  $\mathcal{D}$  are in normal form. We next show how to transform  $\mathcal{K} = \langle \mathcal{T}, \mathcal{D} \rangle$  into normal form. First, we replace every axiom  $C \sqsubseteq D \in \mathcal{D}$  with an axiom  $A_C \sqsubseteq A_D$  (with  $A_C, A_D$  new atomic concepts), and add  $A_C = C$  and  $A_D = D$  to the TBox  $\mathcal{T}$  (they are both valid  $\mathcal{EL}^\perp$  expressions); then we apply the classical  $\mathcal{EL}^\perp$  normalisation steps to the axioms in  $\mathcal{T}$ . In this way, we end up with a new knowledge base  $\langle \mathcal{T}', \mathcal{D}' \rangle$  that is in normal form. This transformation still remains time polynomial.

**Example 8.** A normal form of the KB in Example 2 is  $\mathcal{K} = \langle \mathcal{T}, \mathcal{D} \rangle$  with

$$\begin{aligned} \mathcal{T} = \{ & \text{CRBC} \sqsubseteq \text{MRBC}, \\ & \text{ARBC} \sqsubseteq \text{VRBC}, \\ & \text{MRBC} \sqsubseteq \text{VRBC}, \\ & \exists \text{hasN}.\top \sqsubseteq A_1, \\ & A_1 \sqsubseteq \exists \text{hasN}.\top, \\ & A_2 \sqsubseteq \exists \text{hasCM}.\top, \\ & \exists \text{hasCM}.\top \sqsubseteq A_2, \\ & A_1 \sqcap \text{NotN} \sqsubseteq \perp \} \end{aligned}$$

$$\begin{aligned} \mathcal{D} = \{ & \text{VRBC} \sqsubseteq A_2, \\ & \text{VRBC} \sqsubseteq A_1, \\ & \text{MRBC} \sqsubseteq \text{NotN} \} . \end{aligned}$$

Now, we can prove that the ranking procedure gives back equivalent results whether we apply it to  $\mathcal{K} = \langle \mathcal{T}, \mathcal{D} \rangle$  or to its normal form transformation  $\mathcal{K}' = \langle \mathcal{T}', \mathcal{D}' \rangle$ .

**Lemma 13.** *Given an ontology  $\mathcal{K} = \langle \mathcal{T}, \mathcal{D} \rangle$  and the correspondent ontology in normal form  $\mathcal{K}' = \langle \mathcal{T}', \mathcal{D}' \rangle$ ,  $C \sqsubseteq D \in \mathcal{D}_i$  for some  $i$  iff  $A_C \sqsubseteq A_D \in \mathcal{D}'_i$ , where  $A_C$  is the new atomic concept corresponding to  $C$  ( $A_C = C \in \mathcal{T}'$ ), and analogously for  $A_D$  ( $A_D = C \in \mathcal{T}'$ ).*

We conclude with the following proposition showing that we can work directly with KBs in normal form.

**Proposition 14.** *Given an ontology  $\mathcal{K} = \langle \mathcal{T}, \mathcal{D} \rangle$  and its normal form translation  $\mathcal{K}' = \langle \mathcal{T}', \mathcal{D}' \rangle$ , for every pair of  $\mathcal{EL}^\perp$ -concepts  $C, D$ ,  $\mathcal{K} \vdash_{rc} C \sqsubseteq D$  iff  $\mathcal{K}' \vdash_{rc} C \sqsubseteq D$ .*

It is immediate to see that using a KB in normal form, all steps of our RC decision procedure use classical  $\mathcal{EL}^\perp$  TBoxes in normal form (as axioms  $A_C \sqcap \delta_i \sqsubseteq A_D$  are in normal form, too).

### 3.4. Computational Complexity

Classical subsumption can be decided in polynomial time for  $\mathcal{EL}^\perp$  [2]. We next show that our subsumption decision procedure under RC requires a polynomial number of classical subsumption test and, thus, is polynomial overall w.r.t. the size of a KB.

As we have seen, the entire procedure can be reduced to a sequence of classical entailments tests, while all other operations are linearly bound by the size of the KB. Therefore, in order to determine the computational complexity of our method, we have to check, given a KB  $\mathcal{K} = \langle \mathcal{T}, \mathcal{D} \rangle$  as input, how many classical entailment tests are required in the worst case.

It is easily verified that algorithm `Exceptional`( $\mathcal{T}, \mathcal{E}$ ) performs at most  $|\mathcal{E}| \in \mathcal{O}(|\mathcal{D}|)$  subsumption test. Now, let us analyse `ComputeRanking`( $\mathcal{K}$ ). Line 7 requires  $\mathcal{O}(|\mathcal{D}|)$  subsumption test. Lines 8 - 10 require at most  $\mathcal{O}(|\mathcal{D}|^2)$  subsumption tests as at each round  $|\mathcal{E}_{i+1}|$  is  $|\mathcal{E}_i| - 1$  in the worst case. As at each `repeat` round  $|\mathcal{D}^*|$  decreases in size (at line 12) and, thus, the `repeat` loop is iterated at most  $\mathcal{O}(|\mathcal{D}|)$  times. Therefore, `ComputeRanking` requires at most  $\mathcal{O}(|\mathcal{D}|^3)$  subsumption tests. As each subsumption test is polynomially bounded by the size of  $\mathcal{K}$ , we have the following result.

**Proposition 15.** *Given a KB  $\mathcal{K} = \langle \mathcal{T}, \mathcal{D} \rangle$ , the algorithm `ComputeRanking` runs in polynomial time w.r.t. the size of  $\mathcal{K}$ .*

Note that if the KB remains unchanged in between several defeasible subsumption tests, then the ranking procedure needs to be executed only once. Now, consider `RationalClosure`( $\mathcal{K}, \alpha$ ). Lines 1 - 3 require one subsumption test. In line 4, the value of  $n$  is bounded by  $|\mathcal{D}|$  and line 4 requires at most  $\mathcal{O}(|\mathcal{D}|^3)$  subsumption tests. Lines 5 - 7 require one subsumption test.

The loop in lines 11 - 13 is executed at most  $|\mathcal{D}|$  times (as at each loop  $|\mathcal{D}_{\mathfrak{R}}|$  decreases), at each iteration we make one subsumption test only, and there are at most two subsumption test between lines 15 - 18. Hence, `RationalClosure`( $\mathcal{K}, \alpha$ ) requires at most  $\mathcal{O}(|\mathcal{D}|^3 + |\mathcal{D}|)$  subsumption tests. Since each subsumption test is polynomially bounded by the size of  $\mathcal{K}$ , we have the following result.

**Proposition 16.** *The algorithm `RationalClosure`, that decides whether the defeasible inclusion axiom  $C \sqsubseteq D$  is in the RC of  $\mathcal{K} = \langle \mathcal{T}, \mathcal{D} \rangle$ , runs in polynomial time w.r.t. the size of  $\mathcal{K}$ .*

## 4. Extensions of RC

So far, we have considered RC [40, 42, 47]: both the procedural and the semantic characterisations are well defined, and directly model a principle that is at the base

of typicality reasoning, that is, the *presumption of typicality*. Moreover RC is a *syntactically independent* form of closure; that is, all the KBs that are ranked equivalent generate the same RC (that is a property that, as far as we know, none of the closure operations extending RC satisfy). Yet, for many applications it is well-known that the main limitation of RC from an inferential point of view is that an exceptional subclass cannot inherit *any* of the typical properties of its superclass.

**Example 9.** Consider Examples 5 and 7. The mammalian red blood cells are an exceptional subclass of the vertebrate red blood cells since they do not have a nucleus. So, the conflict determining the exceptionality of MRBC is determined by the axioms  $\text{VRBC} \sqsubseteq \exists \text{hasN}.\top$  and  $\text{MRBC} \sqsubseteq \text{NotN}$ , while there is no conflict w.r.t. the axiom  $\text{VRBC} \sqsubseteq \exists \text{hasCM}.\top$ . Hence, we would like still to conclude that mammalian red blood cells have a cell membrane (i.e.,  $\text{MRBC} \sqsubseteq \exists \text{hasCM}.\top$ ). However, as shown in Example 5,  $\text{VRBC} \sqsubseteq \exists \text{hasCM}.\top \in \mathcal{D}_0$  and the rank of MRBC is 1 and, thus, we cannot conclude  $\text{MRBC} \sqsubseteq \exists \text{hasCM}.\top$  under RC.

In order to overcome such inferential limits, some closure operations extending RC have been proposed. We take under consideration here three proposals: an adaptation for  $\mathcal{ALC}$  [21, 45] of the Lexicographic Closure that Lehmann proposed for Propositional Logic [42], an extension of RC based on the use of inheritance nets to identify the axioms taking part to each specific conflict [19], and an extension of RC based on the notion of *justifications* [16]. In the following, we shall briefly explain how to adapt such forms of closure to  $\mathcal{EL}^\perp$ , using as a starting point the polynomial RC procedure for  $\mathcal{EL}^\perp$  presented so far.

#### 4.1. Lexicographic Closure in $\mathcal{EL}^\perp$

The *Lexicographic Closure* (LC) is an extension of RC that Lehmann proposed for Propositional Logic [42]. The author distinguishes between a *prototypical* and a *presumptive* reading of the defeasible conditionals, where (using our formalism) the defeasible subsumption ‘*bird*  $\sqsubseteq$  *fly*’ is read in the former case as ‘*Typical birds fly*’, and in the latter case as ‘*Birds are presumed to fly, unless we are informed of the contrary*’. Lehmann argues that the first reading, modelling the *presumption of typicality*, is correctly modelled by the RC, while he proposes LC to model the second notion, combining the *presumption of typicality* with a *presumption of independence* ([42], Section 3.1), that says that if a class is not typical with respect to one property (e.g., a penguin is a bird that does not fly) we should assume that it still inherits typical properties of a superclass if we are not forced to conclude otherwise (e.g., penguins still have wings and feathers like typical birds).

DL adaptations of LC have been proposed [21, 45]. However, as for RC, the decision procedures make use of negation and disjunction. To adapt them to  $\mathcal{EL}^\perp$ , we are going to reformulate the procedure in [21]. To do so, we may use the fact that LC is based on the same ranking procedure as for RC. Therefore, replacing the ranking procedure with the one presented here is all what is needed to reformulate LC for  $\mathcal{EL}^\perp$ .

First we compute the rank of the axioms in the DBox exactly as for RC (see Section 3.2.1). Now, assume we have a KB  $\mathcal{K} = \langle \mathcal{T}, \mathcal{D} \rangle$  that has been processed by the ranking procedure. That is,  $\mathcal{K} = \langle \mathcal{T}, \mathcal{D} \rangle$  has been transformed, using the ranking procedure in Section 3.2.1, into  $\mathcal{K}^* = \langle \mathcal{T}^*, \mathcal{D}^* \rangle$ , where  $\mathcal{D}^*$  is partitioned into a sequence  $\mathcal{D}_0, \dots, \mathcal{D}_n$ , with each  $\mathcal{D}_i$  containing the defeasible axioms with rank  $i$ . The main difference with RC is the procedure to decide whether a defeasible inclusion  $C \sqsubseteq D$  is in the closure of a KB. Specifically, given the sets  $\mathcal{D}_0, \dots, \mathcal{D}_n$ , we associate with each subset  $\Delta$  of  $\mathcal{D}^*$  an *index* string  $\langle m_0, \dots, m_n \rangle_\Delta$  with  $m_i = |\Delta \cap \mathcal{D}_{n-i}|$ .<sup>7</sup> After that, we build a lexicographic ordering  $\geq_{lex}$  between index strings in the following way (where  $\Delta, \Theta$  are two subsets of  $\mathcal{D}^*$ ):

$$\langle m_0, \dots, m_n \rangle_\Delta \geq_{lex} \langle l_0, \dots, l_n \rangle_\Theta \text{ iff for every } i \text{ (} 0 \leq i \leq n \text{)}$$

- i.  $m_i \geq l_i$ , or
- ii. if  $m_i < l_i$  then there is  $j < i$  with  $m_j > l_j$ .

Next, we define the *seriousness ordering*  $\prec_{ser}$  between two subsets  $\Delta, \Theta$  of  $\mathcal{D}^*$  as

$$\Delta \prec_{ser} \Theta \text{ iff } \langle m_0, \dots, m_n \rangle_\Delta >_{lex} \langle m'_0, \dots, m'_n \rangle_\Theta ,$$

where, as usual,  $>_{lex}$  is the strict part of  $\geq_{lex}$ .<sup>8</sup> Note that there is an inversion in the order of the arguments between the relations  $\prec_{ser}$  and  $\geq_{lex}$ ; such an inversion is due to the fact that, dealing with preference relations (as  $\prec_{ser}$  is), there is the common habit to consider the ‘lower’ element as the preferred one, and we have preserved such an interpretation also in the case of  $\prec_{ser}$ , which is in agreement with the other preference relations we consider in this paper.

**Remark 6.** *Note that for  $\Theta \subseteq \Delta$ , we always have that  $\Delta \prec_{ser} \Theta$ , i.e., a set is more serious than (is preferred to) any of its subsets.*

<sup>7</sup>That is,  $m_0$  is the number of axioms from  $\mathcal{D}_n$  contained in  $\Delta$ ,  $m_1$  is the number of axioms from  $\mathcal{D}_{(n-1)}$  in  $\Delta$ , and so on.

<sup>8</sup>You may read  $\Delta \prec_{ser} \Theta$  as ‘ $\Delta$  is more serious than  $\Theta$ ’.

We recap that the aim of the lexicographic closure is to maximise the amount of defeasible information that can be associated with a concept  $C$ , that is, the preferred sets of defeasible axioms (i.e., the minimal ones w.r.t.  $\prec_{ser}$ ) that are consistent with  $C$  w.r.t. the KB.

So, for every  $\Theta \subseteq \mathcal{D}^*$  and new atomic concept  $\delta_\Theta$ , we define a new TBox  $\mathcal{T}_\Theta$  as<sup>9</sup>

$$\mathcal{T}_\Theta = \mathcal{T} \cup \{C \sqcap \delta_\Theta \sqsubseteq D \mid C \sqsubseteq D \in \Theta\} . \quad (3)$$

The decision step is eventually the following.

**Definition 7** (Inference relation  $\vdash_{lex}$ ). *Let  $\mathcal{K} = \langle \mathcal{T}, \mathcal{D} \rangle$  be the output of the algorithm `ComputeRanking`, with  $\mathcal{D}$  partitioned into  $\mathcal{D}_0, \dots, \mathcal{D}_n$ , and consider a defeasible subsumption axiom  $C \sqsubseteq D$ . Let  $\min_{C, \prec_{ser}}(\mathcal{D})$  be the set containing the sets  $\Theta \subseteq \mathcal{D}$  s.t.*

- $\mathcal{T}_\Theta \not\models C \sqcap \delta_\Theta \sqsubseteq \perp$ ,
- for all the  $\Delta \subseteq \mathcal{D}$  s.t.  $\Delta \prec_{ser} \Theta$ ,  $\mathcal{T}_\Delta \models C \sqcap \delta_\Delta \sqsubseteq \perp$ .

That is,  $\min_{C, \prec_{ser}}(\mathcal{D})$  is the set of most serious subsets of  $\mathcal{D}$  that are compatible with  $C$ . Now, if  $\min_{C, \prec_{ser}}(\mathcal{D}) \neq \emptyset$  then

$$\mathcal{K} \vdash_{lex} C \sqsubseteq D \text{ iff } \forall \Theta \in \min_{C, \prec_{ser}}(\mathcal{D}), \mathcal{T}_\Theta \models C \sqcap \delta_\Theta \sqsubseteq D ,$$

otherwise (case  $\min_{C, \prec_{ser}}(\mathcal{D}) = \emptyset$ )

$$\mathcal{K} \vdash_{lex} C \sqsubseteq D \text{ iff } \mathcal{T} \models C \sqsubseteq D .$$

**Example 10** (Example 9 cont.). *Consider the output  $\langle \langle \mathcal{T}^*, \mathcal{D}^* \rangle, \mathfrak{R} \rangle$  of the ranking procedure as Example 5. Let us check whether  $\text{MRBC} \sqsubseteq \exists \text{hasCM.T}$  holds under lexicographic entailment (recall that the axiom is not entailed under  $RC$ , see Example 9). To this end, we have to find out which are the most serious subsets of  $\mathcal{D}$  that are compatible with  $\text{MRBC}$ , i.e.  $\min_{\text{MRBC}, \prec_{ser}}(\mathcal{D})$ . It can be shown that  $|\min_{\text{MRBC}, \prec_{ser}}(\mathcal{D})| = 1$  and it contains*

$$\mathcal{D}' = \{\text{VRBC} \sqsubseteq \exists \text{hasCM.T}, \text{MRBC} \sqsubseteq \text{NotN}\} .$$

It is easily verified that

$$\mathcal{T}_{\mathcal{D}'} \models \text{MRBC} \sqcap \delta_{\mathcal{D}'} \sqsubseteq \text{hasCM.T} ,$$

holds and, consequently,  $\mathcal{K} \vdash_{lex} \text{MRBC} \sqsubseteq \exists \text{hasCM.T}$ .

---

<sup>9</sup>See in comparison Eq. (1).

The following example illustrates a case in which we have more than one most serious set of defeasible information.

**Example 11.** Consider the following KB  $\mathcal{K} = \langle \mathcal{T}, \mathcal{D} \rangle$ :

$$\mathcal{T} = \{C \sqcap D = F, F \sqcap E \sqsubseteq \perp, C \sqsubseteq H, D \sqsubseteq H\}$$

$$\mathcal{D} = \{A \sqsubseteq G, A \sqsubseteq C, A \sqsubseteq D, A \sqcap B \sqsubseteq E\} .$$

We ask whether we can conclude  $A \sqcap B \sqsubseteq G$  and  $A \sqcap B \sqsubseteq H$  under LC.

$A \sqcap B$  is an exceptional class w.r.t.  $A$  because of the axioms  $C \sqcap D = F, F \sqcap E \sqsubseteq \perp$ . It can be verified that under RC we would be able to derive neither  $A \sqcap B \sqsubseteq G$  nor  $A \sqcap B \sqsubseteq H$ . Instead, under LC we have two subsets of  $\mathcal{D}$  that, among the subsets of  $\mathcal{D}$  that are compatible with  $A \sqcap B$ , are the most serious ones:

$$\Delta' = \{A \sqsubseteq G, A \sqsubseteq D, A \sqcap B \sqsubseteq E\}$$

$$\Delta'' = \{A \sqsubseteq G, A \sqsubseteq C, A \sqcap B \sqsubseteq E\}.$$

Either using  $\Delta'$  or using  $\Delta''$  we can conclude both  $A \sqcap B \sqsubseteq G$  and  $A \sqcap B \sqsubseteq H$ , that consequently are in the LC of  $\mathcal{K}$ , i.e.,

$$\mathcal{K} \vdash_{lex} A \sqcap B \sqsubseteq G$$

$$\mathcal{K} \vdash_{lex} A \sqcap B \sqsubseteq H.$$

In any case, let us recall the following property stating that any conclusion that can be drawn under RC holds under LC as well.

**Proposition 17.** Given a knowledge base  $\mathcal{K} = \langle \mathcal{T}, \mathcal{D} \rangle$ , then for every pair of  $\mathcal{EL}^\perp$ -concepts  $C, D$ , if  $\mathcal{K} \vdash_{rc} C \sqsubseteq D$  then  $\mathcal{K} \vdash_{lex} C \sqsubseteq D$ .

The intuition behind this property is as follows. Given  $\mathcal{K} = \langle \mathcal{T}, \mathcal{D} \rangle$ , let  $\langle \langle \mathcal{T}^*, \mathcal{D}^* \rangle, \mathfrak{R} \rangle$  be the output of the ranking procedure and consider a concept  $C$ .

- Under RC, we associate to  $C$  a set of inclusions  $\mathcal{D}_i \cup \dots \cup \mathcal{D}_n$ , represented via  $\mathcal{T}_{\delta_i}$ , where  $i$  is the rank of  $C$ .
- Under LC instead, we associate to  $C$ , a set of sets  $\Theta_1, \dots, \Theta_j$  which are those in  $\min_{C, \prec_{ser}}(\mathcal{D})$ . These are represented by the TBoxes  $\mathcal{T}_{\Theta_1}, \dots, \mathcal{T}_{\Theta_j}$ .
- It can be shown that each  $\Theta_k$  is a superset of  $\mathcal{D}_i \cup \dots \cup \mathcal{D}_n$  from which Proposition 17 follows.

**Remark 7.** *As a consequence, the candidate sets  $\Theta$  to look for in order to determine  $\min_{C, \prec_{ser}}(\mathcal{D})$  can be built by adding to  $\mathcal{D}_i \cup \dots \cup \mathcal{D}_n$  any possible strict subset  $\Psi \subset \mathcal{D}_0 \cup \dots \cup \mathcal{D}_{i-1}$ , with  $\Psi \subset \mathcal{D}_j$  ( $0 \leq j \leq i-1$ )<sup>10</sup> i.e.*

$$\Theta = \Psi \cup \mathcal{D}_i \cup \dots \cup \mathcal{D}_n .$$

Proposition 17, together with Remark 7 and the definition of  $\prec_{ser}$  allow us to define Algorithm `LexicographicClosure` which decides defeasible entailment under LC.

*Computational Complexity.* Let us determine the computational complexity of the `LexicographicClosure` algorithm. Lines 1 - 17 are essentially the same as the `RationalClosure` algorithm and, thus, require at most  $\mathcal{O}(|\mathcal{D}|^3 + |\mathcal{D}|)$  subsumption tests. To compute  $\min_{C, \prec_{ser}}(\mathcal{D})$ , each loop in between lines 24 - 39 involves two subsumption test. Let us determine now the number of such loops. It can easily be verified that in the worst case, we run over all possible subsets  $\Theta' = \Psi_j \cup \mathcal{D}_i \cup \dots \cup \mathcal{D}_n$ , where  $\Psi_j \subseteq \mathcal{D}_0 \cup \dots \cup \mathcal{D}_{i-1}$  and, thus, we may have  $\mathcal{O}(2^{|\mathcal{D}|})$  loops. Therefore, in the worst case the loop in between lines 24 - 39 may require as many as  $\mathcal{O}(2^{|\mathcal{D}|})$  subsumption tests. Furthermore, note that the elements in  $\min C$ , i.e.  $\min_{C, \prec_{ser}}(\mathcal{D})$ , all have the same cardinality and, thus, the size of  $\min C$  is bounded by  $\binom{|\mathcal{D}|}{k}$ , for some positive  $k \geq |\overline{\mathcal{D}}|$ . That is,  $|\min C|$  is bounded by  $2^{|\mathcal{D}|}$ .<sup>11</sup> Consequently, lines 43 - 45, may require  $\mathcal{O}(2^{|\mathcal{D}|})$  subsumption tests as well. Hence, we have

**Proposition 18.** *The algorithm `LexicographicClosure`, that decides whether the defeasible inclusion axiom  $C \sqsubseteq D$  is in the LC of  $\mathcal{K} = \langle \mathcal{T}, \mathcal{D} \rangle$ , may require in worst case  $\mathcal{O}(2^{|\mathcal{D}|})$   $\mathcal{EL}^\perp$  subsumption tests, each of which runs in polynomial time w.r.t. the size of  $\mathcal{K}$ .*

**Remark 8.** *Note that the exponential amount of subsumption tests seems to be an inherent property of LC and indeed, exhibits the same behaviour [21]. However, unlike other approaches [21], where the decision procedure makes use of negation and disjunction, here we may entirely rely on a  $\mathcal{EL}^\perp$ , polynomial time subsumption decision procedure and, thus, `LexicographicClosure` may be more efficient in practice.*

#### 4.2. Defeasible Inheritance-based Description Logics

Another extension of RC for DLs is the defeasible inheritance-based approach [19]. In such an approach the axioms in the TBox and in the DBox are translated into

---

<sup>10</sup>Recall that  $C$ 's rank is  $i$ .

<sup>11</sup>More precisely, from  $\binom{|\mathcal{D}|}{k} = \binom{|\mathcal{D}|}{n-k}$  it follows that the maximum of the function  $f(k) = \binom{|\mathcal{D}|}{k}$  is reached at  $\lfloor |\mathcal{D}|/2 \rfloor$  and, thus,  $|\min C|$  is bounded by  $\binom{|\mathcal{D}|}{\lfloor |\mathcal{D}|/2 \rfloor}$ , which asymptotically tends to  $2^{|\mathcal{D}|}$ .

1  
2  
3  
4  
5  
6  
7 an inheritance net, which extends [55]; such a construction allows to apply the RC  
8 procedure locally, in such a way that if we want to decide whether  $C \sqsubseteq D$  holds, the  
9 exceptionality ranking and the RC are calculated considering only the information in  
10 the KB that has some connection to  $C$  and  $D$  (for more details, we refer the reader  
11 to [19]).

12 The adaptation of the inheritance-based decision procedure [19] to  $\mathcal{EL}^\perp$  can be  
13 formalised in the following way. First of all, we assume that a KB  $\langle \mathcal{T}, \mathcal{D} \rangle$  has already  
14 been transformed into *normal form*, as discussed in Section 3.3. Then, we create an  
15 inheritance net  $\mathbf{N}_\mathcal{K}$  representing the content of the KB. The procedure is essentially  
16 the one presented by Casini and Straccia [19]. That is, given a KB  $\langle \mathcal{T}, \mathcal{D} \rangle$ :

- 17 1. for every atomic concept appearing in the axioms in  $\mathcal{K}$ , we create a correspond-
- 18 ing node in the net;
- 19 2. for every axiom  $A \sqsubseteq B \in \mathcal{D}$ , we add the defeasible link  $A \rightarrow B$  to the net;
- 20 3. for every axiom  $A \sqcap B \sqsubseteq \perp \in \mathcal{T}$  we add the symmetric incompatibility link
- 21  $A \not\Leftarrow B$  to the net;
- 22 4. for all the remaining axioms (in normal form)  $C \sqsubseteq D \in \mathcal{T}$ , we introduce (if
- 23 not already present) two nodes in the net representing the concepts  $C$  and  $D$ ,
- 24 respectively, and add the strict connection  $C \Rightarrow D$  to the net;
- 25 5. we then complete the inheritance net  $\mathbf{N}_\mathcal{K}$  doing a total classification of the
- 26 concepts appearing as nodes in the net. That is, for concepts  $C, D$ , where  $C$
- 27 and concept  $D$  are either atomic concepts or of the form  $\exists R.F$ , and  $E$  (not
- 28 being  $\top$ ), that have a node representation in  $\mathbf{N}_\mathcal{K}$ , if  $\mathcal{T} \models C \sqcap D \sqsubseteq E$  holds then
- 29 (a) if  $C \sqcap D \sqsubseteq E$  is in normal form then we add also a link  $C, D \Leftrightarrow^\sqcap E$  (the
- 30 conjunction of  $C$  and  $D$  is subsumed by  $E$ ) to the net  $\mathbf{N}_\mathcal{K}$ ;
- 31 (b) otherwise we first normalise  $C \sqcap D \sqsubseteq E$  into axioms  $\tau_i$  of the form  $\exists R.F \sqsubseteq$
- 32  $A$  or  $A \sqsubseteq \exists R.F$  and into one axiom of the form  $A_1 \sqcap A_2 \sqsubseteq F$ . Then, the
- 33 axioms  $\tau_i$  are addressed as by Step 4. before, while for axiom  $A_1 \sqcap A_2 \sqsubseteq F$
- 34 we add a link  $A_1, A_2 \Leftrightarrow^\sqcap F$  to  $\mathbf{N}_\mathcal{K}$ .

35 Note that nodes in  $\mathbf{N}_\mathcal{K}$  represent concepts that are either  $\perp, \top$  atomic, of the form  
36  $\exists R.F$  or the conjunction of two atomic concepts.

37 Then, in order to decide a query  $A \sqsubseteq B$ , we take under consideration all the  
38 *ducts* starting in  $A$  and ending into  $B$ ; a *duct* is a kind of path that takes under  
39 consideration also the conjunctions, represented by the links ' $\Leftrightarrow^\sqcap$ ' (see [19], Definition  
40 3.2).

41 We shall use the Greek letters  $\pi, \sigma, \dots$  to indicate the ducts. Informally, a duct  
42  $\pi = \langle C, \sigma, D \rangle$  starts in node  $C$ , passes through the links in  $\sigma$ , and ends into node  $D$ .  
43 Specifically,

**Definition 8** (Duct). Ducts are defined as follows (where  $\star \in \{\Rightarrow, \not\Rightarrow, \rightarrow\}$ ):

1. every link  $C \star D$  in  $\mathbf{N}$  is a duct  $\pi = \langle C, D \rangle$  in  $\mathbf{N}$ ;
2. if  $\pi = \langle C, \sigma, D \rangle$  is a duct and  $D \star E$  is a link in  $\mathbf{N}$  that does not already appear in  $\sigma$ , then  $\pi' = \langle C, \sigma, E \rangle$  is a duct in  $\mathbf{N}$ ;
3. if  $\pi = \langle C, \sigma, D \rangle$  is a duct and  $E \star C$  is a link in  $\mathbf{N}$  that does not already appear in  $\sigma$ , then  $\pi' = \langle E, \sigma, D \rangle$  is a duct in  $\mathbf{N}$ ;
4. if  $\langle C, \sigma, D \rangle$  and  $\langle C, \sigma', E \rangle$  are ducts and  $D, E \Leftrightarrow^\square F$  is a link in  $\mathbf{N}$  that does not already appear in  $\langle C, \sigma, D \rangle$  and in  $\langle C, \sigma', E \rangle$ ,  $\langle C, \frac{\sigma, D}{\sigma', E}, F \rangle$  is a duct.

Given a node representing  $C$  and a node representing  $D$ , we consider only the axioms in  $\langle \mathcal{T}, \mathcal{D} \rangle$  corresponding to links appearing in the ducts from  $C$  to  $D$ , and we compute the RC of only such a portion of the KB.

Specifically, the procedure for the closure of a KB  $\langle \mathcal{T}, \mathcal{D} \rangle$  using the Defeasible Inheritance-based approach is as follows [19]:

**Step 1.** Given  $\mathcal{K} = \langle \mathcal{T}, \mathcal{D} \rangle$ , check if  $\mathcal{K}$  is ranked consistent, i.e. check if the RC of  $\mathcal{K}$  is consistent. If it is consistent, then define an inheritance net  $\mathbf{N}_{\mathcal{K}}$  from  $\mathcal{K}$ , as illustrated before.

**Step 2.** Set  $\mathcal{D}_{in} = \mathcal{D}$ .

For every pair of nodes  $\langle C, D \rangle$  such that  $C$  and  $D$  appear in the net  $\mathbf{N}_{\mathcal{K}}$ , do the following:

- compute the set of all ducts starting in  $C$  and ending into  $D$ , and let  $\Delta_{C,D}$  be the set of all the defeasible links  $E \rightarrow F$  appearing in such ducts;
- consider the KB  $\mathcal{K}' = \langle \mathcal{T}, \mathcal{D}' \rangle$ , where  $\mathcal{D}' \subseteq \mathcal{D}$  is the set of the defeasible axioms corresponding to the defeasible links in  $\Delta_{C,D}$ ;
- if  $C \sqsubseteq D$  is in the RC of  $\mathcal{K}'$  (i.e.  $\mathcal{K}' \vdash_{rc} C \sqsubseteq D$ ), then add  $C \sqsubseteq D$  to  $\mathcal{D}_{in}$ .

**Step 3.** Finally, let  $\mathcal{K}_{in} = \langle \mathcal{T}, \mathcal{D}_{in} \rangle$ . Compute the RC of  $\mathcal{K}_{in}$  and eventually define the non-monotonic inference relation  $\vdash_{in}$  as

$$\mathcal{K} \vdash_{in} C \sqsubseteq D \text{ iff } \mathcal{K}_{in} \vdash_{rc} C \sqsubseteq D .$$

The above procedure is illustrated in algorithm `InheritanceBasedRationalClosure`( $\mathcal{K}, \alpha$ ).

1  
2  
3  
4  
5  
6  
7  
8  
9  
10  
11  
12  
13  
14  
15  
16  
17  
18  
19  
20  
21  
22  
23  
24  
25  
26  
27  
28  
29  
30  
31  
32  
33  
34  
35  
36  
37  
38  
39  
40  
41  
42  
43  
44  
45  
46  
47  
48  
49  
50  
51  
52  
53  
54  
55  
56  
57  
58  
59  
60  
61  
62  
63  
64  
65

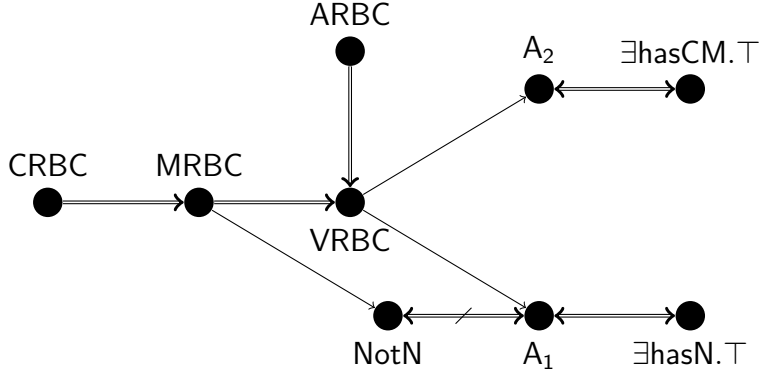

Figure 1: Inheritance net built from Example 12.

**Example 12** (Example 8 cont.). Consider Example 8. The inheritance net  $\mathbf{N}_{\mathcal{K}}$  built from  $\mathcal{K}$  is illustrated in Figure 1.

We want to check whether  $\mathcal{K} \vdash_{in} \text{MRBC} \sqsubseteq \exists \text{hasCM.T}$  holds. To do so, we compute all ducts between MRBC and  $\text{hasCM.T}$ . Actually, there is only one and it includes the defeasible link representing  $\text{VRBC} \sqsubseteq \text{A}_2$ . Therefore, in Step 10. of the `InheritanceBasedRationalClosure` algorithm, we set  $\mathcal{D}' = \{\text{VRBC} \sqsubseteq \text{A}_2\}$ .

It can be verified that  $\text{MRBC} \sqsubseteq \text{A}_2$  is in the RC of  $\mathcal{K}' = \langle \mathcal{T}, \mathcal{D}' \rangle$  and, thus, by Step. 13,  $\text{MRBC} \sqsubseteq \text{A}_2$  is added to  $\mathcal{D}_{in}$ , from which  $\mathcal{K} \vdash_{in} \text{MRBC} \sqsubseteq \exists \text{hasCM.T}$  follows.

*Computational Complexity.* Let us now address the computational complexity of the `InheritanceBasedRationalClosure` algorithm. To start with, that the normalisation Step 1 can be done in linear time from [2], yielding a normalised KB whose size is linear in the size of  $\mathcal{K}$ .

From the result in Section 4 it follows that Step 2 requires at most  $\mathcal{O}(|\mathcal{D}|^3 + |\mathcal{D}|)$  subsumption tests.

Let us now estimate the cost of Step 5. The first step of the construction of  $\mathbf{N}_{\mathcal{K}}$  creates as many nodes as there are atomic concepts in  $\mathcal{K}$  and, thus, both size and time bound is  $\mathcal{O}(|\mathcal{K}|)$ . The second step is obviously bounded both in time and size of number of edges by  $\mathcal{O}(|\mathcal{D}|)$ . Similarly, the third and fourth step can be done together and is bounded both in time and size of number of new nodes and edges by  $\mathcal{O}(|\mathcal{T}|)$ . Therefore, so far Steps 1 - 4. can be done in time  $\mathcal{O}(|\mathcal{K}|)$ , while for network  $\mathbf{N}_{\mathcal{K}}$ , the number of both nodes and edges is bounded by  $\mathcal{O}(|\mathcal{K}|)$ . Eventually, it can easily be verified that including the fifth step of the construction of  $\mathbf{N}_{\mathcal{K}}$ , the overall time bound of the construction of  $\mathbf{N}_{\mathcal{K}}$  is time and size (number of nodes as well as edges) bounded by  $\mathcal{O}(|\mathcal{K}|^2)$ .

1  
2  
3  
4  
5  
6  
7  
8  
9  
10  
11  
12  
13  
14  
15  
16  
17  
18  
19  
20  
21  
22  
23  
24  
25  
26  
27  
28  
29  
30  
31  
32  
33  
34  
35  
36  
37  
38  
39  
40  
41  
42  
43  
44  
45  
46  
47  
48  
49  
50  
51  
52  
53  
54  
55  
56  
57  
58  
59  
60  
61  
62  
63  
64  
65

The number of iterations of Steps 7 - 12 is bounded by  $\mathcal{O}(|\mathcal{K}|^4)$ , as there are at most  $\mathcal{O}(|\mathcal{K}|^2)$  nodes in  $\mathbf{N}_{\mathcal{K}}$ . Step 8 is the same step as illustrated by Casini and Straccia [19], in which it is shown that  $\Delta_{C,D}$  can be computed in polynomial time w.r.t. the size of  $\mathcal{K}$  (Sections 3.1.6 and 3.2.5 [19]). For ease of presentation, let us indicate with  $\delta_{\mathcal{K}}$  the time bound to compute  $\Delta_{C,D}$ . Moreover, the size of both  $\Delta_{C,D}$  and  $\mathcal{D}'$  is bounded by  $\mathcal{O}(|\mathcal{D}|)$  and, thus, the size of  $\mathcal{K}'$  is bounded by  $\mathcal{O}(|\mathcal{K}|)$ . Therefore, Step 12 requires at most  $\mathcal{O}(|\mathcal{D}|^3 + |\mathcal{D}|)$  subsumption tests. In summary, the computation time of iterations Steps 7 - 12 is bounded by  $\mathcal{O}(\delta_{\mathcal{K}} \cdot |\mathcal{K}|^4)$  plus the time required to perform  $\mathcal{O}(|\mathcal{K}|^4(|\mathcal{D}|^3 + |\mathcal{D}|))$  subsumption tests.

Finally, the size of  $\mathcal{D}_{in}$  is bounded by  $\mathcal{O}(|\mathcal{K}|^2)$  and, thus, Step 15 may require at most  $\mathcal{O}(|\mathcal{K}|^6 + |\mathcal{K}|^2)$  subsumption tests.

Therefore, we have the following result.

**Proposition 19.** *The algorithm `InheritanceBasedRationalClosure`, that decides whether the defeasible inclusion axiom  $C \sqsubseteq D$  is in the Inheritance-based RC of  $\mathcal{K} = \langle \mathcal{T}, \mathcal{D} \rangle$ , i.e. decides whether  $\mathcal{K} \vdash_{in} C \sqsubseteq D$  holds, runs in polynomial time w.r.t. the size of  $\mathcal{K}$ .*

### 4.3. Relevant Closure

*Relevant Closure* [16] is another form of closure that extends RC and is defined so far for  $\mathcal{ALC}$  and DLs beyond it. Relevant closure is based on the ranking procedure for RC, but given a KB  $\langle \mathcal{T}, \mathcal{D} \rangle$  and a query  $C \sqsubseteq D$ , it identifies just the parts of the KB that are relevant w.r.t. the particular query.

Specifically, we assume that we have already applied the ranking procedure (algorithm `ComputeRanking`) to the KB, that is, all the classical knowledge is contained in the TBox and the DBox  $\mathcal{D}$  is partitioned into  $\{\mathcal{D}_1, \dots, \mathcal{D}_n\}$ . Now, given a query  $C \sqsubseteq D$ , informally, the part of the KB that is relevant w.r.t. the query is the part of the KB that causes conflicts that make  $C$  exceptional. That is, given  $\mathcal{K} = \langle \mathcal{T}, \mathcal{D} \rangle$  and a query  $C \sqsubseteq D$  we identify all the *justifications* for the (possible) exceptionality of  $C$ , that is, all the information in  $\mathcal{K}$  that causes  $C$  to be exceptional.

**Definition 9 (Justification).** *For  $\mathcal{K} = \langle \mathcal{T}, \mathcal{D} \rangle$ ,  $\mathcal{J} \subseteq \mathcal{D}$ , and concept  $C$ ,  $\mathcal{J}$  is a  $C$ -justification w.r.t.  $\mathcal{K}$  iff  $C$  is exceptional for  $\langle \mathcal{T}, \mathcal{J} \rangle$  (i.e.  $\top \sqsubseteq \neg C$  is rationally entailed by  $\langle \mathcal{T}, \mathcal{J} \rangle$ ) and for every  $\mathcal{J}' \subset \mathcal{J}$ ,  $C$  is not exceptional for  $\langle \mathcal{T}, \mathcal{J}' \rangle$ .*

The notion of justification, combined with our decision procedure to determine exceptionality (algorithm `Exceptional`), gives us the following procedural characterisation of the above defined notion.

**Corollary 20.**  $\mathcal{J}$  is a  $C$ -justification w.r.t.  $\mathcal{K} = \langle \mathcal{T}, \mathcal{D} \rangle$  iff  $\mathcal{J} \subseteq \mathcal{D}$  and for new atom  $\delta$

$$\mathcal{T} \cup \{C \sqcap \delta \sqsubseteq D \mid C \sqsubseteq D \in \mathcal{J}\} \models C \sqcap \delta \sqsubseteq \perp ,$$

and for every  $\mathcal{J}' \subset \mathcal{J}$ ,

$$\mathcal{T} \cup \{C \sqcap \delta \sqsubseteq D \mid C \sqsubseteq D \in \mathcal{J}'\} \not\models C \sqcap \delta \sqsubseteq \perp .$$

The choice of the term *justification* is not accidental, since it closely mirrors the notion of a justification for classical DLs, where a justification for a sentence  $\alpha$  is a minimal set implying  $\alpha$  [39] (it corresponds also to the notion of *kernel* in the base-revision literature [38]).

The principle of Relevant Closure is to consider as defeasible only the information that is in the justification of the antecedent of the query, that is, only the information that creates conflicts that make the antecedent exceptional. All the rest of the information contained in the KB is not considered eliminable. In this way we can preserve the *presumption of independence*. The main procedure is the *Basic Relevant Closure*, whose adaptation to  $\mathcal{EL}^\perp$  is explained next.

1. Let  $\mathcal{K} = \langle \mathcal{T}, \mathcal{D} \rangle$  be a KB s.t. all the classical information is contained in the TBox  $\mathcal{T}$  and the DBox  $\mathcal{D}$  has been partitioned into  $\{\mathcal{D}_0, \dots, \mathcal{D}_n\}$ . Let  $C \sqsubseteq D$  be our query.
2. Compute the set  $\mathcal{J}^{\mathcal{K}}(C) = \{\mathcal{J}_1, \dots, \mathcal{J}_m\}$  of all  $C$ -justifications w.r.t.  $\mathcal{K}$ .
3. Let  $\overline{\mathcal{J}} := \bigcup_{j=1}^m \mathcal{J}_j$  be the union of all  $C$ -justifications w.r.t.  $\mathcal{K}$ .
4.  $i := 0$ .
5. Let  $\mathcal{J}'_i := \overline{\mathcal{J}} \cap \bigcup_{j \geq i} \mathcal{D}_j$ .
6. Check whether

$$\mathcal{T} \cup \{E \sqcap \delta \sqsubseteq F \mid E \sqsubseteq F \in \mathcal{D} \setminus \overline{\mathcal{J}}\} \cup \{E \sqcap \delta \sqsubseteq F \mid E \sqsubseteq F \in \mathcal{J}'_i\} \models C \sqcap \delta \sqsubseteq \perp .$$

- (a) If that's true and  $i < n$ , set  $i := i + 1$  and go to Step 5.
  - (b) If that's true and  $i = n$ , set  $\mathcal{J}'_i := \emptyset$  and proceed to the next step.
  - (c) If it is not the case then proceed to the next step.
7. Finally,  $C \sqsubseteq D$  is in the Basic Relevant Closure of  $\mathcal{K}$  iff

$$\mathcal{T} \cup \{E \sqcap \delta \sqsubseteq F \mid E \sqsubseteq F \in \mathcal{D} \setminus \overline{\mathcal{J}}\} \cup \{E \sqcap \delta \sqsubseteq F \mid E \sqsubseteq F \in \mathcal{J}'_i\} \models C \sqcap \delta \sqsubseteq D .$$

The above procedure is illustrated in the algorithm `BasicRelevantClosure`.

**Example 13** (Example 9 cont.). Consider Example 9 and the query  $\text{MRBC} \sqsubseteq \text{hasCM}.\top$ . By running the `BasicRelevantClosure` algorithm, it can be verified that the only MRBC-justification is the set

$$\mathcal{J}_1 := \{\text{VRBC} \sqsubseteq \exists \text{hasN}.\top, \text{MRBC} \sqsubseteq \text{NotN}\}$$

and  $\overline{\mathcal{J}} = \mathcal{J}_1$ . Therefore,  $\text{VRBC} \sqsubseteq \text{hasCM}.\top$  is in the set  $\mathcal{D} \setminus \overline{\mathcal{J}}$  and, thus, the axiom  $\text{MRBC} \sqsubseteq \text{hasCM}.\top$  is in the Basic Relevant Closure of  $\mathcal{K}$ .

The algorithm `BasicRelevantClosure` can be refined in order to improve the inferential power, obtaining the *Minimal Relevant Closure* [16]. The difference between the Basic and the Minimal version of the Relevant Closure is that the latter, given a query  $C \sqsubseteq D$  and the set  $\mathcal{J}^{\mathcal{K}}(C)$  containing the  $C$ -justifications, of every justification in  $\mathcal{J}^{\mathcal{K}}(C)$  we consider as relevant only the axioms that are more prone to be eliminated by the RC procedure, that is, the axioms with the lower rank.

So, given a justification  $\mathcal{J}$ , let

$$\mathcal{J}_{\min}^{\mathcal{K}} := \{D \sqsubseteq E \mid r_{\mathcal{K}}(D) \leq r_{\mathcal{K}}(F) \text{ for every } F \sqsubseteq G \in \mathcal{J}\},$$

and

$$\mathcal{J}_{\min} := \bigcup_{\mathcal{J} \in \mathcal{J}^{\mathcal{K}}(C)} \mathcal{J}_{\min}^{\mathcal{K}}.$$

The procedure for *Minimal Relevant Closure* corresponds exactly to the one for the Basic Closure, simply using  $\mathcal{J}_{\min}$  as the relevant set of axioms, instead of  $\overline{\mathcal{J}}$ . Algorithm `MinimalRelevantClosure` details the procedure for Minimal Relevant Closure.

The following example shows the different inferential behaviour of Minimal Relevant Closure w.r.t. Basic Relevant Closure.

**Example 14** (Example 13 cont.). Consider the KB in Example 13. Now, suppose that we also know that mammalian sickle cells are mammalian red blood cells, that mammalian red blood cells normally have a bioconcave shape, but that mammalian sickle cells normally do not (they normally have a crescent shape). We represent this new information as

$$\mathcal{T}' = \mathcal{T} \cup \{\text{MSC} \sqsubseteq \text{MRBC}, \exists \text{hasS}.\text{BC} \sqcap \exists \text{hasS}.\text{Cr} \sqsubseteq \perp\}$$

and

$$\mathcal{D}' = \mathcal{D} \cup \{\text{MRBC} \sqsubseteq \exists \text{hasS}.\text{BC}, \text{MSC} \sqsubseteq \exists \text{hasS}.\text{Cr}\}.$$

1  
2  
3  
4  
5  
6  
7 Consider now the query of whether mammalian sickle cells don't have a nucleus, that  
8 is, whether  $\text{MSC} \sqsubseteq \text{NotN}$  is in the Minimal Relevant Closure.

9 To this end, consider KB  $\mathcal{K}' = \langle \mathcal{T}', \mathcal{D}' \rangle$ . Please note now that there are two  
10 MSC-justifications w.r.t.  $\mathcal{K}$ , namely

$$\begin{aligned} \mathcal{J}^1 &= \{\text{MRBC} \sqsubseteq \text{NotN}, \text{VRBC} \sqsubseteq \exists \text{hasN}.\top\} \\ \mathcal{J}^2 &= \{\text{MRBC} \sqsubseteq \exists \text{hasS}.\text{BC}, \text{MSC} \sqsubseteq \exists \text{hasS}.\text{Cr}\} . \end{aligned}$$

11  
12  
13  
14  
15  
16 *Basic Relevant Closure.* To check whether  $\text{MSC} \sqsubseteq \text{notN}$  is in the Basic Relevant Clo-  
17 sure of  $\mathcal{K}'$  we have to consider as irrelevant, and hence not eliminable, only the axiom  
18  $\text{VRBC} \sqsubseteq \exists \text{hasCM}.\top$  (the only axiom that does not appear in any MSC-justification),  
19 while all the other defeasible axioms appear in some MSC-justification and are eligible  
20 for being eliminating during the procedure. It turns out that  $\text{MSC} \sqsubseteq \neg \exists \text{hasN}.\top$  is not  
21 in the Basic Relevant Closure of  $\mathcal{K}'$  since  $\text{MRBC} \sqsubseteq \text{notN}$  is eliminated by the proce-  
22 dure for Basic Relevant Closure, and hence  $\text{MSC} \sqsubseteq \text{notN}$  is not in the Basic Relevant  
23 Closure of  $\mathcal{K}'$ .  
24  
25

26  
27 *Minimal Relevant Closure.* On the other hand, to check if  $\text{MSC} \sqsubseteq \text{notN}$  is in the  
28 Minimal Relevant Closure, please note that  $\mathcal{J}_{\min}^1 = \{\text{VRBC} \sqsubseteq \exists \text{hasN}.\top\}$ , and  $\mathcal{J}_{\min}^2 =$   
29  $\{\text{MRBC} \sqsubseteq \exists \text{hasS}.\text{BC}\}$ . Thus, the axiom  $\text{MRBC} \sqsubseteq \text{notN}$  is not relevant in the mini-  
30 mal framework and, thus, not eliminable. Therefore,  $\text{MSC} \sqsubseteq \text{notN}$  is in the Minimal  
31 Relevant Closure of  $\mathcal{K}'$ .  
32

33  
34 *Computational Complexity.* Even if developed with a different motivation (ontology  
35 repairing) the results by Ludwig et al. [44] are relevant w.r.t. our proposal: the paper  
36 shows that the identification of justifications in  $\mathcal{EL}$  is not a polynomial problem (a  
37 consequence of their Corollary 14) and, thus, neither are the decision problem of Basic  
38 Relevant Closure entailment nor the one of Minimal Relevant Closure entailment for  
39  $\mathcal{EL}^\perp$ .  
40

41  
42 **Proposition 21.** *Basic Relevant Closure and Minimal Relevant Closure entailment*  
43 *problems cannot be decided in polynomial time.*  
44

45 However, Ludwig et al. [44] also proposes a way to precompile repairs and label  
46 axioms that can be easily readapted to our problem. That is, we can precompile  
47 justifications and label the axioms depending on which justifications they take part  
48 into. Once we have done this precompilation of the justifications, which however  
49 may take exponential time w.r.t. the size of  $\mathcal{K}$ , after that the decision problem of  
50 Basic Relevant Closure entailment and Minimal Relevant Closure entailment can be  
51 resolved in polynomial time, as it is then a special case of the RC procedure (this is  
52 an immediate consequence of Proposition 16).  
53  
54  
55  
56

## 5. Conclusions and Closely Related Work

In this work, we have presented a novel algorithm to decide subsumption under RC in the DL  $\mathcal{EL}^\perp$ . The main contribution is that the subsumption problem under RC can be decided in polynomial time, as is the case for monotonic  $\mathcal{EL}^\perp$ , and thus, the result extends to OWL 2 EL [50] as well. Specifically, we have shown that our algorithm may decide subsumption under RC via a polynomial number of classical  $\mathcal{EL}^\perp$  subsumption tests. Furthermore, we have adapted the algorithm also to some extensions of RC for DLs, such as the Lexicographic Closure, Defeasible Inheritance-based DLs and (Basic/Minimal) Relevant Closure. Additionally, for them, we have shown that the subsumption problem remains polynomial for Defeasible Inheritance-based  $\mathcal{EL}^\perp$  only.<sup>12</sup>

As the basic language requirement is, besides the possibility to express unsatisfiable KBs,<sup>13</sup> to have conjunction on the left-hand side of GCIs, our procedure can be adapted to any other DL  $\mathcal{L}$  having this feature as well (e.g. OWL 2 RL [51]). Furthermore, subsumption under RC for  $\mathcal{L}$  may be decided using a polynomial number of classical  $\mathcal{L}$  subsumption tests. Therefore, if the classical subsumption problem for  $\mathcal{L}$  is in the complexity class  $\mathcal{C}$  then the subsumption problem under RC is in  $\mathcal{C}$  as well if  $\mathcal{C}$  is in P or higher, else it is in P. So, e.g. the subsumption problem under RC is in P for *DL-Lite*<sub>horn</sub><sup>H</sup> [1].

These results are non-trivial. Indeed, as pointed out in the introduction, non-monotonic DLs extensions usually do not preserve the tractability of  $\mathcal{EL}^\perp$  [6, 9, 12, 15, 16, 18, 19, 21, 20, 25, 27, 28, 30, 45]. An exception is the novel (but non-RC-based) approach proposed by Bonatti et al. [7], which is tractable for *any* tractable classical DL, and the specific  $\mathcal{EL}$  fragment based on circumscription proposed by Bonatti et al. [9, 8]).

Concerning future work, one of our aims is to determine whether the subsumption problem under RC still remains polynomial for various other tractable DLs of the *DL-Lite* family [1] that however do not support conjunction on the left-hand side of GCIs.

---

<sup>12</sup>Relevant Closure cannot be polynomial for  $\mathcal{EL}^\perp$ , our algorithm runs in exponential time for Lexicographic Closure and non-polynomiality is suspected, but not yet proved.

<sup>13</sup>Otherwise, defeasible axioms do not cause any issue.

## Appendix A. Proofs

**Proposition 1** For an ontology  $\mathcal{K} = \langle \mathcal{T}, \mathcal{D} \rangle$  and a defeasible axiom  $C \sqsubseteq D$ ,  $\mathcal{K} \models_{\mathfrak{R}} C \sqsubseteq D$  iff

$$\forall R \in \mathfrak{R}_{\Delta}^{\mathcal{K}}, R \models C \sqsubseteq D .$$

*Proof.* Let  $\Delta$  be a countable infinite domain. If  $\mathcal{K} \models_{\mathfrak{R}} C \sqsubseteq D$ , then obviously  $\forall R \in \mathfrak{R}_{\Delta}^{\mathcal{K}}, R \models C \sqsubseteq D$ .

On the other hand, assume  $\forall R \in \mathfrak{R}_{\Delta}^{\mathcal{K}}, R \models C \sqsubseteq D$ . We have to prove that it is not possible that there is some  $R$  in  $\mathfrak{R}^{\mathcal{K}}$  s.t.  $R \not\models C \sqsubseteq D$ . Let  $R$  be a model of  $\mathcal{K}$  and a counter-model of  $C \sqsubseteq D$ . We can easily prove that for a defeasible language built over the DL  $\mathcal{ALC}$  (or any of  $\mathcal{ALC}$ -sublanguages) and semantically characterised by the class of the ranked models, the Finite Model Property (and the Finite Counter-Model Property) holds (see Section Appendix A.1). Then, if we have a ranked interpretation  $R$  that is a model of  $\mathcal{K}$  and a counter-model of  $C \sqsubseteq D$  (with a domain that could be countable or uncountable), there must be a model  $R_{fin}$  with a finite domain that is also a model of  $\mathcal{K}$  and a counter-model of  $C \sqsubseteq D$ . Given  $R_{fin}$ , then we can extend it to a model of  $\mathcal{K}$  that is a counter-model of  $C \sqsubseteq D$  with a countable infinite domain. Hence, if there is a counter model of  $\mathcal{K} \models_{\mathfrak{R}} C \sqsubseteq D$ , there must be also a counter model with a countable domain, and we can consider only the models with a countable infinite domain in the definition of  $\models_{\mathfrak{R}}$ .

Now, let  $R' = \langle \Delta', \cdot^{R'}, \preceq^{R'} \rangle$  be a model of  $\mathcal{K}$  and a counter-model of  $C \sqsubseteq D$  with  $\Delta'$  countable infinite. It is easy to build an isomorphic interpretation  $R = \langle \Delta, \cdot^R, \preceq^R \rangle$ : once we have defined a bijection  $b : \Delta' \times \Delta$  (that must exist, being both  $\Delta'$  and  $\Delta$  countable infinite sets), we can define  $\cdot^R$  and  $\preceq^R$  in the following way:

- For every  $r \in \mathbf{N}_{\mathcal{R}}$  and every  $x, y \in \Delta'$ ,  $\langle b(x), b(y) \rangle \in r^R$  iff  $\langle x, y \rangle \in r^{R'}$ ;
- For every  $C \in \mathbf{N}_{\mathcal{C}}$  and every  $x \in \Delta'$ ,  $b(x) \in C^R$  iff  $x \in C^{R'}$ ;
- For every  $x, y \in \Delta'$ ,  $b(x) \preceq^R b(y)$  iff  $x \preceq^{R'} y$ .

It is easy to prove by induction on the construction of the concepts that for every concept  $C$ ,  $x \in C^{R'}$  iff  $b(x) \in C^R$ ; moreover,  $x \in \min_{\preceq^{R'}}(C^{R'})$  iff  $b(x) \in \min_{\preceq^R}(C^R)$ . Hence, if there is a counter model to  $\mathcal{K} \models_{\mathfrak{R}} C \sqsubseteq D$  there must be also a counter model with  $\Delta$  as domain.

Hence, we can use just the set of interpretations in  $\mathfrak{R}_{\Delta}^{\mathcal{K}}$  to decide the consequences of  $\mathcal{K}$  w.r.t. ranked entailment.  $\square$

**Proposition 2** Let  $\mathcal{K}$  be an ontology having a ranked model. Then  $R_{\mathcal{K}}^{\cup}$  is a model of  $\mathcal{K}$  and for any pair of concepts  $C, D$ ,  $R_{\mathcal{K}}^{\cup} \models C \sqsubseteq D$  iff  $r_{\mathcal{K}}(C \sqcap D) < r_{\mathcal{K}}(C \sqcap \neg D)$  or  $r_{\mathcal{K}}(C) = \infty$ .

*Proof.* First of all, given  $\mathcal{K} = \langle \mathcal{T}, \mathcal{D} \rangle$ , we have to prove that the exceptionality function

$$E_{\mathcal{T}}(\mathcal{D}) = \{C \sqsubseteq D \mid \mathcal{K} \models_{\mathfrak{R}} \top \sqsubseteq \neg C\}$$

is correctly represented in this model. By Proposition 1, the exceptionality function can be reformulated as

$$E_{\mathcal{T}}(\mathcal{D}) = \{C \sqsubseteq D \mid \forall R \in \mathfrak{R}_{\Delta}^{\mathcal{K}}, R \models \top \sqsubseteq \neg C\}$$

that clearly corresponds to saying that

$$E_{\mathcal{T}}(\mathcal{D}) = \{C \sqsubseteq D \mid R_{\mathcal{K}}^{\cup} \models \top \sqsubseteq \neg C\}.$$

If we are dealing with a language without a negation operator, as  $\mathcal{EL}^{\perp}$ , the correspondent condition is

$$E_{\mathcal{T}}(\mathcal{D}) = \{C \sqsubseteq D \mid \min_{\leq R_{\mathcal{K}}^{\cup}}(\Delta^{R_{\mathcal{K}}^{\cup}}) \cap C^{R_{\mathcal{K}}^{\cup}} = \emptyset\}.$$

Now we have to prove that this correspondence is preserved for all the steps of the exceptionality function, that is, we have to prove that the model  $R_{\mathcal{K}}^{\cup}$  is a correct semantical representation of the ranking procedure. That corresponds to saying that for every concept  $C$  and every  $i$ ,  $0 < i \leq n$ ,

$$r_{\mathcal{K}}(C) = i \text{ iff } h_{R_{\mathcal{K}}^{\cup}}(C) = i.$$

We can prove it by induction on the rank value  $i$  ( $i > 0$ ).

If  $h_{R_{\mathcal{K}}^{\cup}}(C) = i$  it is immediate that  $r_{\mathcal{K}}(C) \leq i$ . We have now to prove that if  $r_{\mathcal{K}}(C) = i$  then  $h_{R_{\mathcal{K}}^{\cup}}(C) = i$ . We can prove that by defining a model  $R$  in  $\mathfrak{R}^{\mathcal{K}}$  s.t.  $h_R(C) = i$ .

So, given a KB  $\mathcal{K} = \langle \mathcal{T}, \mathcal{D} \rangle$ , let  $r_{\mathcal{K}}(C) = i$ , and let  $\mathcal{D}_{\geq i}^r$  be the subset of  $\mathcal{D}$  containing the defeasible axioms with a rank value of at least  $i$ . Let  $M$  be a ranked model of  $\langle \mathcal{T}, \mathcal{D}_{\geq i}^r \rangle$  s.t.  $h_M(C) = 0$ ; such a model must exist, since  $r_{\mathcal{K}}(C) = i$ , that is,  $C$  is not exceptional in  $\langle \mathcal{T}, \mathcal{D}_{\geq i}^r \rangle$ . We assume that  $M$  has a finite domain (we can, due to the FMP).

Now, let  $N$  be a model of  $\langle \mathcal{T}, \mathcal{D} \rangle$  in  $\mathfrak{R}_{\Delta}^{\mathcal{K}}$  s.t. for all the axioms  $C \sqsubseteq D \in (\mathcal{D} \setminus \mathcal{D}_{\geq i}^r)$  there is an individual satisfying  $C \sqcap D$ . The induction hypothesis guarantees that such a model exists. We define a new interpretation  $N'$  in the following way:

- $L_0^{N'} = L_0^N$ ;

- 1  
2  
3  
4  
5  
6  
7 ...  
8  
9 •  $L_{i-1}^{N'} = L_{i-1}^N$ ;  
10  
11 •  $L_i^{N'} = L_i^N \cup L_0^M$ ;  
12  
13 •  $L_{i+1}^{N'} = L_{i+1}^N \cup L_1^M$ ;  
14  
15 ...  
16

17 and so on, for all the layers of both  $N$  and  $M$ .  $N'$  is a model of  $\langle \mathcal{T}, \mathcal{D} \rangle$  (easy to  
18 prove) s.t.  $h_{N'}(C) = i$ . Since  $N'$  is obtained from the composition of a model with  
19  $\Delta$  as domain and a model with a finite domain, it too has a countable domain and  
20 there is a model  $N'_\Delta$  that is isomorphic to  $N'$  and has  $\Delta$  as domain. So  $N'_\Delta$  takes  
21 part in the construction of  $R_{\mathcal{K}}^\cup$ , and  $h_{R_{\mathcal{K}}^\cup}(C) = i$ .

22 This proves that for every  $C$ ,  $r_{\mathcal{K}}(C) = i$  iff  $h_{R_{\mathcal{K}}^\cup}(C) = i$ .

23 Eventually, since  $R_{\mathcal{K}}^\cup \models C \sqsubseteq D$  iff  $h_{R_{\mathcal{K}}^\cup}(C \sqcap D) < h_{R_{\mathcal{K}}^\cup}(C \sqcap \neg D)$  (or  $h_{R_{\mathcal{K}}^\cup}(C) = \infty$ ),  
24 and  $h_{R_{\mathcal{K}}^\cup}(C \sqcap D) < h_{R_{\mathcal{K}}^\cup}(C \sqcap \neg D)$  (or  $h_{R_{\mathcal{K}}^\cup}(C) = \infty$ ) iff  $r_{\mathcal{K}}(C \sqcap D) < r_{\mathcal{K}}(C \sqcap \neg D)$  (or  
25  $r(C) = \infty$ ), this concludes the proof of the proposition.  $\square$

26  
27  
28  
29  
30 **Proposition 4** For an ontology  $\mathcal{K} = \langle \mathcal{T}, \mathcal{E} \rangle$  and  $C \sqsubseteq D \in \mathcal{E}$ , if  $\mathcal{T}_{\delta_{\mathcal{E}}} \models C \sqcap \delta_{\mathcal{E}} \sqsubseteq \perp$   
31 then for every model  $R \in \mathfrak{R}^{\mathcal{K}}$ ,  $C^R \cap \min_{\prec_R}(\Delta^R) = \emptyset$ .

32  
33 *Proof.* If  $\mathcal{K}$  is not ranked consistent (i.e.,  $\mathcal{K}$  does not have a ranked model), the  
34 proposition is trivially satisfied. Hence, assume  $\mathcal{K}$  is ranked consistent.

35 So, let  $R = \langle \Delta^R, \cdot^R, \preceq^R \rangle$  a ranked model of  $\mathcal{K}$ , defined over a signature  $\mathbf{N}_{\mathcal{E}} \cup \mathbf{N}_{\mathcal{R}}$ .  
36 We define a classical model  $\mathcal{I}_{\delta}^R = \langle \Delta^R, \cdot^{\mathcal{I}_{\delta}^R} \rangle$  in the following way.

- 37  
38  
39 •  $\mathcal{I}_{\delta}^R$  is defined over a new signature  $\mathbf{N}'_{\mathcal{E}} \cup \mathbf{N}_{\mathcal{R}}$ , with  $\mathbf{N}'_{\mathcal{E}} = \mathbf{N}_{\mathcal{E}} \cup \{\delta_{\mathcal{E}}\}$ ;  
40  
41 • for every  $r \in \mathbf{N}_{\mathcal{R}}$ ,  $r^{\mathcal{I}_{\delta}^R} = r^R$ ;  
42  
43 • for every  $C \in \mathbf{N}_{\mathcal{E}}$ ,  $C^{\mathcal{I}_{\delta}^R} = C^R$ ;  
44  
45 • for every  $x \in \Delta^R$ ,  $x \in \delta^{\mathcal{I}_{\delta}^R}$  iff  $x \in \min_{\prec_R}(\Delta^R)$ .  
46

47 It is easy to check that if  $R$  is a model of  $\langle \mathcal{T}, \mathcal{E} \rangle$ , then  $\mathcal{I}_{\delta}^R$  is a model of  $\mathcal{T}_{\delta_{\mathcal{E}}}$ : by  
48 induction on the construction of the concepts, it is immediate that for every concept  
49  $C$  generated from the signature  $\mathbf{N}_{\mathcal{E}} \cup \mathbf{N}_{\mathcal{R}}$  and every  $x \in \Delta^R$ ,  $x \in C^R$  iff  $x \in C^{\mathcal{I}_{\delta}^R}$ .  
50 Now, assume there is an axiom  $C \sqsubseteq D \in \mathcal{T}_{\delta_{\mathcal{E}}}$  s.t.  $\mathcal{I}_{\delta}^R \not\models C \sqsubseteq D$ . If  $C \sqsubseteq D \in \mathcal{T}$ , it  
51 is immediate that  $R \not\models C \sqsubseteq D$ , that cannot be the case. Instead, if  $C \sqsubseteq D$  has the  
52 form  $E \sqcap \delta_{\mathcal{E}} \sqsubseteq D$ , then if  $E^R \cap \min_{\prec_R}(\Delta^R) \neq \emptyset$  we conclude  $R \not\models E \sqsubseteq D$  (that cannot  
53  
54  
55  
56  
57  
58  
59  
60  
61  
62  
63  
64  
65

1  
2  
3  
4  
5  
6  
7  
8  
9  
10  
11  
12  
13  
14  
15  
16  
17  
18  
19  
20  
21  
22  
23  
24  
25  
26  
27  
28  
29  
30  
31  
32  
33  
34  
35  
36  
37  
38  
39  
40  
41  
42  
43  
44  
45  
46  
47  
48  
49  
50  
51  
52  
53  
54  
55  
56  
57  
58  
59  
60  
61  
62  
63  
64  
65

be the case, since  $E \sqsubseteq D \in \mathcal{E}$ ), while if  $E^R \cap \min_{\prec_R}(\Delta^R) = \emptyset$  it cannot be the case that  $\mathcal{I}_\delta^R \not\models C \sqsubseteq D$ , since  $(E \cap \delta_\mathcal{E})^{\mathcal{I}_\delta^R} = \emptyset$  and so there is no object in  $\Delta^R$  satisfying the antecedent. At this point it is immediate to see also that  $C^R \cap \min_{\prec_R}(\Delta^R) = \emptyset$  iff  $\mathcal{I}_\delta^R \models C \cap \delta_\mathcal{E} \sqsubseteq \perp$ .

So, if every model of  $\mathcal{T}_{\delta_\mathcal{E}}$  satisfies  $C \cap \delta_\mathcal{E} \sqsubseteq \perp$ , we have that, for every ranked model  $R$  of  $\mathcal{K}$ ,  $C^R \cap \min_{\prec_R}(\Delta^R) = \emptyset$ : if it was not the case for any model  $R'$ , at least one model of  $\mathcal{T}_\delta$  (the model  $\mathcal{I}_\delta^{R'}$  created from  $R'$ ) would not satisfy  $C \cap \delta_\mathcal{E} \sqsubseteq \perp$ .  $\square$

**Corollary 5** *If a defeasible axiom  $C \sqsubseteq D$  is in the fixed point of the exceptionality procedure, i.e. at some step of the algorithm `ComputeRanking`,  $C \sqsubseteq D \in \mathcal{D}_\infty$ , then  $C \sqsubseteq D \in \mathcal{D}'_\infty$ .*

*Proof.* The result is a direct consequence of the correctness of the exceptionality function w.r.t. the ranking procedure of RC (Proposition 4). Given a KB  $\mathcal{K} = \langle \mathcal{T}, \mathcal{D} \rangle$ , if at every step  $j$ ,  $E^j(\mathcal{D})$  is a subset of the axioms that are of rank  $j$  w.r.t. the RC of  $\mathcal{K}$ , and  $C \sqsubseteq D$  is in the fixed point of the function  $E$ , then  $C \sqsubseteq D$  is also in the fixed point of the RC ranking procedure.  $\square$

**Proposition 6** *The ontology  $\langle \mathcal{T}^*, \mathcal{D}^* \rangle$  is ranked equivalent to the ontology  $\langle \mathcal{T}, \mathcal{D} \rangle$ .*

*Proof.* It is immediate to see that  $\langle \mathcal{T}^*, \mathcal{D}^* \rangle$  implies  $\langle \mathcal{T}, \mathcal{D} \rangle$  w.r.t. ranked entailment, since  $C \sqsubseteq \perp \models_R C \sqsubseteq D$  for all the concepts  $C, D$ .

On the other hand, that  $\langle \mathcal{T}, \mathcal{D} \rangle$  implies  $\langle \mathcal{T}^*, \mathcal{D}^* \rangle$  is a direct consequence of Corollary 5, that implies that  $\langle \mathcal{T}, \mathcal{D} \rangle \models_R C \sqsubseteq \perp$  for every  $C \sqsubseteq \perp \in \mathcal{T}^* \setminus \mathcal{T}$ .  $\square$

**Proposition 8** *Let  $\mathcal{K} = \langle \mathcal{T}, \mathcal{D} \rangle$  be an ontology base s.t.  $\mathcal{D}_\infty = \emptyset$ . For  $C \sqsubseteq D \in \mathcal{D}$ , if  $C^R \cap \min_{\prec_R} \Delta^R = \emptyset$  for every model  $R \in \mathfrak{R}^\mathcal{K}$ , then  $\mathcal{T}_{\delta_\mathcal{D}} \models C \cap \delta_\mathcal{D} \sqsubseteq \perp$ .*

*Proof.* Since the fixed point is empty, we have also that no axiom in  $\mathcal{D}$  has infinite rank (see Lemma 22 below).

Assume that there is an interpretation  $\mathcal{I} = \langle \Delta^\mathcal{I}, \cdot^\mathcal{I} \rangle$  that is a model of  $\mathcal{T}_\delta$  and there is an object  $a$  s.t.  $a^\mathcal{I} \in (C \cap \delta)^\mathcal{I}$ . We have to prove that then there is a ranked model  $R$  of  $\langle \mathcal{T}, \mathcal{D} \rangle$  s.t.  $C^R \cap \min_{\prec_R} \Delta^R \neq \emptyset$ .

At first, we build a model  $R^\mathcal{I} = \langle \Delta^\mathcal{I}, \cdot^\mathcal{I}, \preceq^{R^\mathcal{I}} \rangle$  in the following way. We have a ranking of the set  $\mathcal{D}$  into  $\mathcal{D}_1^r, \dots, \mathcal{D}_n^r$  ( $\mathcal{D}_1^r, \dots, \mathcal{D}_n^r$  is the partition of  $\mathcal{D}$  obtained using the classical RC ranking procedure); assign to every object in  $\Delta^\mathcal{I}$  a layer w.r.t. the defeasible axioms it satisfies, that is, an object  $x$  is in  $L_i$  iff either  $x \in (C \cap D)^\mathcal{I}$  or  $x \notin C^\mathcal{I}$  for every axiom  $C \sqsubseteq D$  in every set  $\mathcal{D}_j^r$ ,  $i \leq j \leq n$ , and, if  $i \geq 1$ , there is an axiom  $E \sqsubseteq F$  in  $\mathcal{D}_{i-1}^r$  s.t.  $x \in C^\mathcal{I}$  and  $x \notin D^\mathcal{I}$ . Note that, since  $\mathcal{I}$  is a model of  $\mathcal{T}_\delta$ , all the individuals falling under  $\delta^\mathcal{I}$  necessarily end up into the lower layer  $L_0$ .

1  
2  
3  
4  
5  
6  
7 Consider each set of defeasible axioms  $\mathcal{D}_i^r$ . An object  $x$  satisfies the axioms in  
8  $\mathcal{D}_i^r$  iff for every  $C \sqsubseteq D \in \mathcal{D}_i^r$  either  $x$  falls under the concept  $C \sqcap D$  (the individual  
9 *realises* the axiom) or  $x$  does not fall under  $C$  (the individual does not realise the  
10 axiom). Consider all possible combinations (consistent with  $\langle \mathcal{T}, \mathcal{D} \rangle$ ) of realisations  
11 and non-realizations of the axioms in  $\mathcal{D}_i^r$ : we want to be sure to have an individual  
12 in  $L_i$  that satisfies each such combination. If for some combination there is none,  
13 then create one individual and add it to the layer and modify the domain and the  
14 interpretation function accordingly. It is possible that the creation of such individual  
15 forces also the creation of other individuals related to it through some role; in such a  
16 case create them and add them to some layer accordingly to the constraints specified  
17 here above. The construction of the ranking procedure assures us that for every  
18  $C \sqsubseteq D \in \mathcal{D}_i^r$  it is possible to add an individual realising it (otherwise  $C \sqsubseteq D \in \mathcal{D}_\infty^r$ ,  
19 but we have assumed that  $\mathcal{D}_\infty^r = \emptyset$ ).

20  
21  
22  
23 The final model we obtain is a model of  $\langle \mathcal{T}, \mathcal{D} \rangle$ , since it is a model of  $\mathcal{T}$  and for  
24 every axiom in  $\mathcal{D}$  there is at least an individual satisfying  $C \sqcap D$  that is preferred to all  
25 the other individuals satisfying  $C$  and not  $D$ . In such a model,  $C^R \cap \min_{\prec_R} \Delta^R \neq \emptyset$   
26 since we have an individual  $a$  originally satisfying  $C \sqcap \delta$ , that consequently now  
27 satisfies  $C$  and is in  $L_0$ .  $\square$

28  
29  
30 **Lemma 22** (\*). *Let  $\langle \mathcal{T}, \mathcal{D} \rangle$  be an ontology base s.t.  $\mathcal{D}_\infty = \emptyset$ . Then there is no*  
31  *$C \sqsubseteq D \in \mathcal{D}$  s.t.  $r_{\mathcal{K}}(C \sqsubseteq D) = \infty$ .*

32  
33  
34 *Proof.* If  $\mathcal{D}_\infty = \emptyset$  then we have partitioned the set  $\mathcal{D}$  into  $\mathcal{D}_0, \dots, \mathcal{D}_n$ . Note that if  
35  $\mathcal{D}_\infty = \emptyset$ , it must be that the TBox  $\mathcal{T}_{\delta_0}$  (and, of course, all its subsets) is consistent.

36 Consider now the ontology  $\langle \mathcal{T}, \mathcal{D}_n \rangle$  and the correspondent classical TBox  $\mathcal{T}_{\delta_n}$ .  
37 For each  $C \sqsubseteq D$  in  $\mathcal{D}_n$  there must be at least a classical model  $\mathcal{J}$  of  $\mathcal{T}_{\delta_n}$  s.t.  $\mathcal{J} \not\models$   
38  $C \sqcap \delta_n \sqsubseteq \perp$ . Take one such model for each  $C \sqsubseteq D$  in  $\mathcal{D}_n$ , and let  $\mathcal{I} = \langle \Delta^{\mathcal{I}}, \cdot^{\mathcal{I}} \rangle$  be the  
39 interpretation obtained by unifying all such models. It is immediate to see that  $\mathcal{I}$  is  
40 a model of  $\mathcal{T}_{\delta_n}$  such that  $\mathcal{I} \not\models C \sqcap \delta_n \sqsubseteq \perp$  for any  $C \sqsubseteq D$  in  $\mathcal{D}_n$ . Let's define a ranked  
41 model  $R^{\mathcal{I}} = \langle \Delta^{\mathcal{I}}, \cdot^{R^{\mathcal{I}}}, \prec^{R^{\mathcal{I}}} \rangle$  in the following way:

- 42  
43  
44
- 45 • If  $\mathbf{N}_{\mathcal{E}} \cup \mathbf{N}_{\mathcal{R}}$  is the signature used of  $\mathcal{I}$ ,  $R^{\mathcal{I}}$  is defined over a new signature  
46  $\mathbf{N}'_{\mathcal{E}} \cup \mathbf{N}_{\mathcal{R}}$ , with  $\mathbf{N}'_{\mathcal{E}} = \mathbf{N}_{\mathcal{E}} \setminus \{\delta_n\}$ ;
  - 47 • for every  $r \in \mathbf{N}_{\mathcal{R}}$ ,  $r^{R^{\mathcal{I}}} = r^{\mathcal{I}}$ ;
  - 48 • for every  $C \in \mathbf{N}'_{\mathcal{E}}$ ,  $C^{R^{\mathcal{I}}} = C^{\mathcal{I}}$ ;
  - 49 • for every  $x, y \in \Delta^{\mathcal{I}}$ ,  $x \prec^{R^{\mathcal{I}}} y$  iff  $x \in \delta_n^{\mathcal{I}}$  and  $y \notin \delta_n^{\mathcal{I}}$ .
- 50  
51  
52  
53  
54  
55  
56

It is easy to see, in an analogous way as for the Proposition 4, that  $R^{\mathcal{I}}$  is a model of  $\langle \mathcal{T}, \mathcal{D}_n \rangle$ , s.t.  $R^{\mathcal{I}} \not\models C \sqsubseteq \perp$  for any  $C \sqsubseteq D \in \mathcal{D}_n$ . Now consider the ontology  $\langle \mathcal{T}, \mathcal{D}_n \cup \mathcal{D}_{n-1} \rangle$  and the correspondent TBox  $\mathcal{T}_{\delta_{n-1}} = \mathcal{T} \cup \{C \sqcap \delta_{i-1} \sqsubseteq D \mid C \sqsubseteq D \in \mathcal{D}_n \cup \mathcal{D}_{n-1}\}$ . Take under consideration each conditional  $C \sqsubseteq D \in \mathcal{D}_{n-1}$ .  $\mathcal{T}_{\delta_{n-1}}$  is consistent and for every  $C \sqsubseteq D \in \mathcal{D}_{n-1}$  we do not derive  $\mathcal{T}_{\delta_{n-1}} \models C \sqcap \delta_{n-1} \sqsubseteq \perp$  for none of the antecedents  $C \sqcap \delta_{n-1}$  of the correspondent conditionals  $C \sqcap \delta_{n-1} \sqsubseteq D$ . Hence, for each  $C \sqsubseteq D \in \mathcal{D}_{n-1}$  there must be a model  $\mathcal{J}_{C|D} = \langle \Delta^{\mathcal{J}_{C|D}}, \cdot^{\mathcal{J}_{C|D}} \rangle$  of  $\mathcal{T}_{\delta_{n-1}}$  s.t.  $\mathcal{J}_{C|D} \not\models C \sqcap \delta_{n-1} \sqsubseteq \perp$ . Note that, by the exceptionality procedure, we must have  $\mathcal{J}_{C|D} \models E \sqcap \delta_{n-1} \sqsubseteq \perp$  for every  $E \sqsubseteq F \in \mathcal{D}_n$ .

Now consider the model  $\mathcal{I}$  and each model  $\mathcal{J}_{C|D}$  (one for each  $C \sqsubseteq D \in \mathcal{D}_{n-1}$ ), and define the interpretation  $\mathcal{I}_{n-1} = \langle \Delta^{\mathcal{I}_{n-1}}, \cdot^{\mathcal{I}_{n-1}} \rangle$  in the following way:

- $\Delta^{\mathcal{I}_{n-1}} = \Delta^{\mathcal{I}} \cup \bigcup \{ \Delta^{\mathcal{J}_{C|D}} \};$
- $\cdot^{\mathcal{I}_{n-1}} = \cdot^{\mathcal{I}} \cup \bigcup \{ \cdot^{\mathcal{J}_{C|D}} \}.$

Now define a ranked model  $R^{\mathcal{I}_{n-1}} = \langle \Delta^{\mathcal{I}_{n-1}}, \cdot^{\mathcal{I}_{n-1}}, \prec^{R^{\mathcal{I}_{n-1}}} \rangle$  in the following way:

- If  $\mathbf{N}_{\mathcal{E}} \cup \mathbf{N}_{\mathcal{D}}$  is the signature used of  $\mathcal{I}_{n-1}$ ,  $R^{\mathcal{I}}$  is defined over a new signature  $\mathbf{N}'_{\mathcal{E}} \cup \mathbf{N}_{\mathcal{D}}$ , with  $\mathbf{N}'_{\mathcal{E}} = \mathbf{N}_{\mathcal{E}} \setminus \{\delta_n, \delta_{n-1}\}$ ;
- for every  $r \in \mathbf{N}_{\mathcal{D}}$ ,  $r^{R^{\mathcal{I}_{n-1}}} = r^{\mathcal{I}_{n-1}}$ ;
- for every  $C \in \mathbf{N}'_{\mathcal{E}}$ ,  $C^{R^{\mathcal{I}_{n-1}}} = C^{\mathcal{I}_{n-1}}$ ;
- for every  $x, y \in \Delta^{\mathcal{I}_{n-1}}$ ,  $x \prec^{R^{\mathcal{I}_{n-1}}} y$  iff  $x \in \delta_{n-1}^{\mathcal{I}_{n-1}}$  and  $y \notin \delta_{n-1}^{\mathcal{I}_{n-1}}$ , or  $x \in \delta_n^{\mathcal{I}_{n-1}}$  and  $y \notin \delta_n^{\mathcal{I}_{n-1}}$ .

Again, it is easy to check that  $R^{\mathcal{I}_{n-1}}$  is a model of  $\langle \mathcal{T}, \mathcal{D}_n \cup \mathcal{D}_{n-1} \rangle$  s.t.  $R^{\mathcal{I}_{n-1}} \not\models C \sqsubseteq \perp$  for any  $C \sqsubseteq D \in \mathcal{D}_n \cup \mathcal{D}_{n-1}$ . We can go on with this procedure until we arrive to  $\mathcal{D}_0$ , obtaining a model  $R$  of  $\langle \mathcal{T}, \mathcal{D} \rangle$  s.t.  $R \not\models C \sqsubseteq \perp$  for any  $C \sqsubseteq D \in \mathcal{D}$ .  $\square$

**Proposition 9** *Given an ontology  $\mathcal{K} = \langle \mathcal{T}, \mathcal{D} \rangle$ , consider the sets  $\mathcal{T}^*, \mathcal{D}_0, \dots, \mathcal{D}_n$  as determined by  $\text{ComputeRanking}(\mathcal{K})$ . Then for every defeasible axiom  $C \sqsubseteq D \in \mathcal{D}$ ,  $r_{\mathcal{K}}(C \sqsubseteq D) = i$  ( $0 \leq i \leq n$ ) iff  $C \sqsubseteq D$  is in  $\mathcal{D}_i$ , and  $r_{\mathcal{K}}(C \sqsubseteq D) = \infty$  iff  $C \sqsubseteq \perp \in \mathcal{T}^*$ .*

*Proof.* An immediate consequence of Proposition 4 is that if  $C \sqsubseteq D$  is in the fixed point of the function  $E_{\mathcal{T}}$  (and so  $C \sqsubseteq \perp$  is in  $\mathcal{T}^*$ ),  $r_{\mathcal{K}}(C \sqsubseteq D) = \infty$ : Proposition 4 guarantees that the set  $E_{\mathcal{T}}(\mathcal{D})$  is a subset of the set of axioms in  $\mathcal{D}$  with rank 1, and then, due to this,  $E_{\mathcal{T}}(E_{\mathcal{T}}(\mathcal{D}))$  just be a subset of the set of axioms in  $\mathcal{D}$  with rank 2, and so on. So,  $C \sqsubseteq \perp \in \mathcal{T}^*$  implies  $r_{\mathcal{K}}(C \sqsubseteq D) = \infty$ .

Since we necessarily end up with a KB  $\langle \mathcal{T}^*, \mathcal{D}^* \rangle$  s.t. the the fixed point of the exceptionality procedure is empty, by Lemma 22 we immediately obtain that if  $r_{\mathcal{K}}(C \sqsubseteq D) = \infty$  then  $C \sqsubseteq \perp \in \mathcal{T}^*$  and, from the combination of the Propositions 4 and 8, the correctness of every application of the function  $E_{\mathcal{T}}$ , that is,  $r_{\mathcal{K}}(C \sqsubseteq D) = i$  ( $0 \leq i \leq n$ ) iff  $C \sqsubseteq D$  is in  $\mathcal{D}_i$ .  $\square$

**Theorem 10** *Given a KB  $\mathcal{K} = \langle \mathcal{T}, \mathcal{D} \rangle$ , its characteristic RC-model  $R_{\mathcal{K}}^{\cup}$ , and a defeasible subsumption axiom  $C \sqsubseteq D$ . Then*

$$\mathcal{K} \vdash_{rc} C \sqsubseteq D \text{ iff } R_{\mathcal{K}}^{\cup} \models C \sqsubseteq D .$$

*Proof.* Immediate from Lemma 23 below.  $\square$

**Lemma 23** (\*). *Given an ontology  $\mathcal{K} = \langle \mathcal{T}, \mathcal{D} \rangle$  and a concept  $C$ ,  $\mathcal{T}_{\delta_i} \not\models C \sqcap \delta_i \sqsubseteq \perp$  iff  $r_{\mathcal{K}}(C) \leq i$ .*

*Proof.* From right to left. Assume  $r_{\mathcal{K}}(C) \leq i$ . Then in the model  $R_{\mathcal{K}}^{\cup}$  there is an individual  $x \in C^{R_{\mathcal{K}}^{\cup}}$  s.t.  $h_{R_{\mathcal{K}}^{\cup}}(x) = i$ . Now define the submodel  $R_{\mathcal{K}_i}^{\cup}$  from  $R_{\mathcal{K}}^{\cup}$  in the following way: consider only the layers  $L_j$  s.t.  $j \geq i$ . If an individual in these layers is connected through a chain of roles to any set of individuals in some  $L_k$ , with  $k < i$ , preserve such individuals and simply ‘move’ them to the highest layer of the model. It is easy to see that  $R_{\mathcal{K}_i}^{\cup}$  is a model of  $\langle \mathcal{T}^*, \mathcal{D}_i \cup \dots \cup \mathcal{D}_n \rangle$ :  $R_{\mathcal{K}}^{\cup}$  is a model of  $\langle \mathcal{T}^*, \mathcal{D}^* \rangle$ , hence  $R_{\mathcal{K}_i}^{\cup}$  is a model of  $\mathcal{T}^*$  too; from Proposition 2 we know that  $r_{\mathcal{K}}(C) = i$  iff  $h_{R_{\mathcal{K}}^{\cup}}(C) = i$ , hence, by Proposition 9, for every axiom  $C \sqsubseteq D$  in  $\mathcal{D}_i \cup \dots \cup \mathcal{D}_n$ ,  $h_{R_{\mathcal{K}_i}^{\cup}}(C \sqcap D) < h_{R_{\mathcal{K}_i}^{\cup}}(C \sqcap \neg D)$ .

Let’s us now define the classical DL-interpretation  $\mathcal{I}^{R_{\mathcal{K}_i}^{\cup}} = \langle \Delta^{R_{\mathcal{K}_i}^{\cup}}, \mathcal{I}^{R_{\mathcal{K}_i}^{\cup}} \rangle$  in the following way:

- $\mathcal{I}^{R_{\mathcal{K}_i}^{\cup}}$  is defined over a new signature  $\mathbf{N}'_{\mathcal{E}} \cup \mathbf{N}_{\mathcal{R}}$ , with  $\mathbf{N}'_{\mathcal{E}} = \mathbf{N}_{\mathcal{E}} \cup \{\delta_i\}$ , where  $\mathbf{N}_{\mathcal{E}} \cup \mathbf{N}_{\mathcal{R}}$  is the signature used in the model  $R_{\mathcal{K}_i}^{\cup}$ ;
- for every  $r \in \mathbf{N}_{\mathcal{R}}$ ,  $r^{\mathcal{I}^{R_{\mathcal{K}_i}^{\cup}}} = r^{R_{\mathcal{K}_i}^{\cup}}$ ;
- for every  $C \in \mathbf{N}_{\mathcal{E}}$ ,  $C^{\mathcal{I}^{R_{\mathcal{K}_i}^{\cup}}} = C^{R_{\mathcal{K}_i}^{\cup}}$ ;
- for every  $x \in \Delta^{R_{\mathcal{K}_i}^{\cup}}$ ,  $x \in \delta^{\mathcal{I}^{R_{\mathcal{K}_i}^{\cup}}}$  iff  $x \in \min_{\prec_{R_{\mathcal{K}_i}^{\cup}}}(\Delta^{R_{\mathcal{K}_i}^{\cup}})$ .

It is easy to see that  $\mathcal{I}^{R_{\mathcal{K}_i}^{\cup}}$  is a model of  $\mathcal{T}_{\delta_i}$ , and  $\mathcal{I}^{R_{\mathcal{K}_i}^{\cup}} \not\models C \sqcap \delta_i \sqsubseteq \perp$ . Hence  $\mathcal{T}_{\delta_i} \not\models C \sqcap \delta_i \sqsubseteq \perp$ , and by monotonicity also  $\mathcal{T}_{\delta_j} \not\models C \sqcap \delta_j \sqsubseteq \perp$ ,  $i \leq j \leq n$ .

From left to right. Assume  $\mathcal{T}_{\delta_i} \not\models C \sqcap \delta_i \sqsubseteq \perp$ . Then there is a model  $\mathcal{I}$  of  $\mathcal{T}_{\delta_i}$  with an object  $x \in \Delta^{\mathcal{I}}$  s.t.  $x \in (C \sqcap \delta_i)^{\mathcal{I}}$ . Divide  $\Delta^{\mathcal{I}}$  in sets  $L_i^{\mathcal{I}}, \dots, L_{n+1}^{\mathcal{I}}$  in the following way:

- for every  $x \in \Delta^{\mathcal{I}}$ ,  $x \in L_j^{\mathcal{I}}$  iff for each axiom  $E \sqsubseteq F$  in  $\mathcal{D}_j \cup \dots \cup \mathcal{D}_n$ , either  $x \in (E \sqcap F)^{\mathcal{I}}$  or  $x \notin E^{\mathcal{I}}$ , and there is an axiom  $E' \sqsubseteq F' \in \mathcal{D}_{j-1}$  s.t.  $x \in E'^{\mathcal{I}}$  and  $x \notin F'^{\mathcal{I}}$ .

Note that every  $x$  s.t.  $x \in \delta_i^{\mathcal{I}}$  must be in  $L_i^{\mathcal{I}}$ . Now combine  $\mathcal{I}$  with  $R_{\mathcal{K}}^{\cup}$  in a ranked interpretation  $R' = \langle \Delta^{R'}, \cdot^{R'}, \prec^{R'} \rangle$  in the following way:

- $\Delta^{R'} = \Delta^{R_{\mathcal{K}}^{\cup}} \cup \Delta^{\mathcal{I}}$ ;
- for every role  $r$ ,  $r^{R'} = r^{R_{\mathcal{K}}^{\cup}} \cup r^{\mathcal{I}}$ ;
- for every concept  $C$ ,  $C^{R'} = C^{R_{\mathcal{K}}^{\cup}} \cup C^{\mathcal{I}}$ ;
- the layers  $L_0^{R'}, \dots, L_n^{R'}$  are organised in the following way:

- $L_0^{R'} = L_0^{R_{\mathcal{K}}^{\cup}}$ ;
- $\vdots$
- $L_{i-1}^{R'} = L_{i-1}^{R_{\mathcal{K}}^{\cup}}$ ;
- $L_i^{R'} = L_i^{R_{\mathcal{K}}^{\cup}} \cup L_i^{\mathcal{I}}$ ;
- $\vdots$
- $L_{n+1}^{R'} = L_{n+1}^{R_{\mathcal{K}}^{\cup}} \cup L_{n+1}^{\mathcal{I}}$ ;

It is easy to prove that  $R'$  is a model of  $\mathcal{K}$  in which we have an object  $x \in C^{R'}$  in the  $i^{\text{th}}$  layer, that is,  $R'$  is a model of  $\mathcal{K}$  s.t.  $h_{R'}(C) \leq i$ . Hence  $r_{\mathcal{K}}(C) \leq i$ .  $\square$

**Proposition 11**  $C \sqsubseteq D$  is in the rational closure of  $\langle \mathcal{T}, \mathcal{D} \rangle$  iff  $\mathcal{T}^* \models C \sqsubseteq D$ .

*Proof.* From right to left it is obvious. For the other direction, assume there is a model  $\mathcal{I}$  of  $\mathcal{T}^*$  that has an object  $a$  s.t.  $a \in C^{\mathcal{I}}$  and  $a \notin D^{\mathcal{I}}$ . Now, we can create a ranked interpretation  $R^{\mathcal{I}}$  of  $\mathcal{I}$  exactly in the same way we have done in the proof of Proposition 8.  $R^{\mathcal{I}}$  would be a model of  $\langle \mathcal{T}, \mathcal{D} \rangle$  s.t.  $R^{\mathcal{I}} \not\models C \sqsubseteq D$ , hence we would have also a countable infinite model of  $\langle \mathcal{T}, \mathcal{D} \rangle$  that does not satisfy  $C \sqsubseteq D$ . Consequently  $R_{\mathcal{K}}^{\cup} \not\models C \sqsubseteq D$ , where  $R_{\mathcal{K}}^{\cup}$  is the characteristic model of the RC of  $\langle \mathcal{T}, \mathcal{D} \rangle$ , and  $C \sqsubseteq D$  would not be in the RC of  $\langle \mathcal{T}, \mathcal{D} \rangle$ .  $\square$

**Corollary 12** *An ontology  $\mathcal{K} = \langle \mathcal{T}, \mathcal{D} \rangle$  is ranked inconsistent iff  $\mathcal{T}^* \models \top \sqsubseteq \perp$ .*

*Proof.* An ontology is ranked inconsistent iff it rationally entails  $\top \sqsubseteq \perp$ , that is, iff it rationally entails  $\top \sqsubseteq \perp$ , that is, by Proposition 11, iff  $\mathcal{T}^* \models \top \sqsubseteq \perp$ .  $\square$

**Lemma 13** *Given an ontology  $\mathcal{K} = \langle \mathcal{T}, \mathcal{D} \rangle$  and the correspondent ontology in normal form  $\mathcal{K} = \langle \mathcal{T}', \mathcal{D}' \rangle$ ,  $C \sqsubseteq D \in \mathcal{D}_i$  for some  $i$  iff  $A_C \sqsubseteq A_D \in \mathcal{D}'_i$ , where  $A_C$  is the new atom corresponding to  $C$  ( $A_C = C \in \mathcal{T}'$ ), and analogously for  $A_D$  ( $A_D = C \in \mathcal{T}'$ ).*

*Proof.* Let  $\langle \mathcal{T}^+, \mathcal{D}^+ \rangle$  the KB obtained adding to  $\mathcal{T}$  the axioms  $\mathcal{A}_C = C$  and  $\mathcal{A}_D = D$  for every axiom  $C \sqsubseteq D \in \mathcal{D}$  ( $A_C, A_D$  being new atomic concepts), while  $\mathcal{D}^+$  is obtained substituting in  $\mathcal{D}$  every axiom  $C \sqsubseteq D$  with  $A_C \sqsubseteq A_D$ . The proposition can be proven by induction on the exceptionality function  $E_{\mathcal{T}}$ . To do that, it is sufficient to prove that for every  $C \sqsubseteq D \in \mathcal{D}$ ,  $\mathcal{T}_{\delta} \models C \sqcap \delta_0 \sqsubseteq \perp$  iff  $\mathcal{T}_{\delta}^+ \models A_C \sqcap \delta_0 \sqsubseteq \perp$ .

From left to right it is immediate, since  $\mathcal{T}_{\delta} \models C \sqsubseteq D$  for every  $C \sqsubseteq D \in \mathcal{T}_{\delta}^+$ .

From right to left, if  $\mathcal{T}_{\delta} \not\models C \sqcap \delta_0 \sqsubseteq \perp$  then there is a model  $\mathcal{I}$  of  $\mathcal{T}_{\delta}$  (that interprets only the concepts appearing in  $\mathcal{T}_{\delta}$ ) s.t.  $(C \sqcap \delta_0)^{\mathcal{I}} \neq \emptyset$ . Extend the interpretation function  $^{\mathcal{I}}$  of  $\mathcal{I}$  in such a way that  $A_C^{\mathcal{I}} = C^{\mathcal{I}}$  for any new concept  $A_C$  introduced in  $\mathcal{T}_{\delta}^+$ ; this new interpretation is a model of  $\mathcal{T}_{\delta}^+$ , so  $\mathcal{T}_{\delta}^+ \not\models A_C \sqsubseteq \perp$ .

Since  $\mathcal{T}'_{\delta}$  is just the normal form of  $\mathcal{T}_{\delta}^+$ , that preserves satisfaction, for every  $C \sqsubseteq D \in \mathcal{D}$ ,  $\mathcal{T}_{\delta} \models C \sqcap \delta_0 \sqsubseteq \perp$  iff  $\mathcal{T}'_{\delta} \models A_C \sqcap \delta_0 \sqsubseteq \perp$ , which concludes.  $\square$

**Proposition 14** *Given an ontology  $\mathcal{K} = \langle \mathcal{T}, \mathcal{D} \rangle$  and its normal form translation  $\mathcal{K}' = \langle \mathcal{T}', \mathcal{D}' \rangle$ , for every pair of  $\mathcal{EL}^{\perp}$ -concepts  $C, D$ ,  $\mathcal{K} \vdash_{rc} C \sqsubseteq D$  iff  $\mathcal{K}' \vdash_{rc} C \sqsubseteq D$ .*

*Proof.* The schema of the proof of Lemma 13 can be used to prove that for every pair of concepts  $C, D$ ,  $i$  is the lowest integer s.t.  $0 \leq i \leq n$  and

$$\mathcal{T}_{\delta_i} \not\models C \sqcap \delta_i \sqsubseteq \perp,$$

and

$$\mathcal{T}_{\delta_i} \models C \sqcap \delta_i \sqsubseteq D$$

iff it is the lowest integer s.t.  $0 \leq i \leq n$  and

$$\mathcal{T}'_{\delta_i} \not\models C \sqcap \delta_i \sqsubseteq \perp,$$

and

$$\mathcal{T}'_{\delta_i} \models C \sqcap \delta_i \sqsubseteq D.$$

$\square$

1  
2  
3  
4  
5  
6  
7 *Appendix A.1. Finite Model Property for Defeasible  $\mathcal{ALC}$  Knowledge Bases*

8 We need to prove that defeasible  $\mathcal{ALC}$  ontologies satisfy the Finite Model Property.  
9 To this end, consider a finite defeasible  $\mathcal{ALC}$  knowledge base  $\mathcal{K} = \langle \mathcal{T}, \mathcal{D} \rangle$ , and let  
10  $R = \langle \Delta^R, \cdot^R, \preceq^R \rangle$  be a ranked model of  $\mathcal{K}$  (with  $\Delta^R$  possibly infinite, and with  $\prec^R$   
11 being the strict part of  $\preceq^R$ ). Let  $\mathbf{N}_\emptyset \cup \mathbf{N}_\mathcal{D}$  be the signature of our language, and let  
12  $\Gamma$  be a set of concepts  $\{C_1, \dots, C_n\}$  s.t.  $\Gamma$  is obtained closing under sub-concepts and  
13 negation the concepts appearing in the axioms in  $\mathcal{K}$ . Now we define the equivalence  
14 relation  $\sim_\Gamma$  as  
15  
16

$$17 \quad \forall x, y \in \Delta^R, x \sim_\Gamma y \text{ iff } \forall C \in \Gamma, x \in C^R \text{ iff } y \in C^R .$$

18  
19 We indicate with  $[a]_\Gamma$  the equivalence class of the individuals that are related to an  
20 individual  $a$  through  $\sim_\Gamma$ :  
21  
22

$$23 \quad [x]_\Gamma = \{y \mid x \sim_\Gamma y\} .$$

24  
25 We introduce the new model  $R' = \langle \Delta^{R'}, \cdot^{R'}, \preceq^{R'} \rangle$ , defined as:  
26  
27

- 28 •  $\Delta^{R'} = \{[x]_\Gamma \mid x \in \Delta^R\}$ ;
- 29 • for every  $A \in \mathbf{N}_\emptyset \cap \Gamma$ ,  $A^{R'} = \{[x]_\Gamma \mid x \in A^R\}$ ;
- 30 • for every  $A \notin \mathbf{N}_\emptyset \cap \Gamma$ ,  $A^{R'} = \emptyset$ ;
- 31 • for every  $r \in \mathbf{N}_\mathcal{D}$ ,  $r^{R'} = \{\langle [x]_\Gamma, [y]_\Gamma \rangle \mid \langle x, y \rangle \in r^R\}$ ;
- 32 • For every  $[x]_\Gamma, [y]_\Gamma \in \Delta^{R'}$ ,  $[x]_\Gamma \preceq^{R'} [y]_\Gamma$  if there is an object  $z \in [x]_\Gamma$  s.t. for all  
33 the objects  $v \in [y]_\Gamma$ ,  $z \prec^R v$ ; otherwise,  $[y]_\Gamma \preceq^{R'} [x]_\Gamma$ .  
34  
35  
36  
37  
38  
39

40 Let  $\prec^{R'}$  and  $\equiv^{R'}$  defined as usual:  
41  
42

- 43 •  $[x]_\Gamma \prec^{R'} [y]_\Gamma$  iff  $[x]_\Gamma \preceq^{R'} [y]_\Gamma$  and  $[y]_\Gamma \not\preceq^{R'} [x]_\Gamma$ ;
- 44 •  $[x]_\Gamma \equiv^{R'} [y]_\Gamma$  iff  $[x]_\Gamma \preceq^{R'} [y]_\Gamma$  and  $[y]_\Gamma \preceq^{R'} [x]_\Gamma$ .  
45  
46

47 Note that  $[x]_\Gamma \prec^{R'} [y]_\Gamma$  iff there is an object  $z \in [x]_\Gamma$  s.t. for all the objects  $v \in [y]_\Gamma$ ,  
48  $z \prec^R v$ , while  $[x]_\Gamma \equiv^{R'} [y]_\Gamma$  iff for every  $z \in [x]_\Gamma$  there is a  $v \in [y]_\Gamma$  s.t.  $v \preceq^R z$ , and  
49 for every  $v \in [y]_\Gamma$  there is a  $z \in [x]_\Gamma$  s.t.  $z \preceq^R v$ .  
50

51 Given that  $\Gamma$  is finite,  $\Delta^{R'}$  is clearly finite. The following results are easy to prove.  
52

53 **Lemma 24.** *For every  $C \in \Gamma$  and every  $x \in \Delta^R$ ,  $x \in C^R$  iff  $[x]_\Gamma \in C^{R'}$ .*  
54  
55  
56

*Proof.* The proof is by straightforward induction on the construction of the concepts.  $\square$

**Lemma 25.** *The preorder  $\preceq^{R'}$  is a modular preorder.*

*Proof.* Reflexivity: Assume  $[a]_{\Gamma} \not\preceq^{R'} [a]_{\Gamma}$ . By the definition of  $\preceq^{R'}$ , it implies that we could not have any  $a' \in [a]_{\Gamma}$  s.t.  $a' \prec^R a''$  for every  $a'' \in [a]_{\Gamma}$ , that in turn would imply  $[a]_{\Gamma} \preceq^{R'} [a]_{\Gamma}$ , and we would have an absurdity.

Transitivity: Assume  $[a]_{\Gamma} \preceq^{R'} [b]_{\Gamma}$  and  $[b]_{\Gamma} \preceq^{R'} [c]_{\Gamma}$ . We have four possible cases.

If  $[a]_{\Gamma} \prec^{R'} [b]_{\Gamma}$  and  $[b]_{\Gamma} \prec^{R'} [c]_{\Gamma}$ , that means that there is an individual  $a' \in [a]_{\Gamma}$  s.t.  $a' \prec^R b'$  for every  $b' \in [b]_{\Gamma}$ , and that there is a  $b^* \in [b]_{\Gamma}$  s.t.  $b^* \prec c'$  for every  $c' \in [c]_{\Gamma}$ . Hence  $a' \prec^R c'$  for every  $c' \in [c]_{\Gamma}$ , and  $[a]_{\Gamma} \prec^{R'} [c]_{\Gamma}$ .

Assume that  $[a]_{\Gamma} \prec^{R'} [b]_{\Gamma}$  and  $[b]_{\Gamma} \equiv^{R'} [c]_{\Gamma}$ . Then there is an individual  $a' \in [a]_{\Gamma}$  s.t.  $a' \prec^R b'$  for every  $b' \in [b]_{\Gamma}$ , for every  $b' \in [b]_{\Gamma}$  there is at least a  $c' \in [c]_{\Gamma}$  s.t.  $c' \preceq^R b'$ , and for every  $c' \in [c]_{\Gamma}$  there is at least a  $b' \in [b]_{\Gamma}$  s.t.  $b' \preceq^R c'$ . It must be the case that  $a' \prec^R c'$  for every  $c' \in [c]_{\Gamma}$ , that is,  $[a]_{\Gamma} \prec^{R'} [c]_{\Gamma}$ ; otherwise we would have that there is a  $c' \in [c]_{\Gamma}$  s.t.  $c' \preceq^R a'$ , that, since there is a  $b' \in [b]_{\Gamma}$  s.t.  $b' \preceq^R c'$ , by the transitivity of  $\preceq^R$  would imply  $b' \preceq^R a'$ , against the hypothesis that  $[a]_{\Gamma} \prec^{R'} [b]_{\Gamma}$ .

Assume that  $[a]_{\Gamma} \equiv^{R'} [b]_{\Gamma}$  and  $[b]_{\Gamma} \prec^{R'} [c]_{\Gamma}$ . There must be a  $b' \in [b]_{\Gamma}$  s.t.  $b' \prec^R c'$  for every  $c' \in [c]_{\Gamma}$ , and there must be an  $a' \in [a]_{\Gamma}$  s.t.  $a' \preceq^R b'$ . Hence  $a' \prec^R c'$  for every  $c' \in [c]_{\Gamma}$ , and we can conclude that  $[a]_{\Gamma} \prec^{R'} [c]_{\Gamma}$ .

Assume that  $[a]_{\Gamma} \equiv^{R'} [b]_{\Gamma}$  and  $[b]_{\Gamma} \equiv^{R'} [c]_{\Gamma}$ . Then it is easy to check for every  $a' \in [a]_{\Gamma}$  there must be a  $c' \in [c]_{\Gamma}$  s.t.  $c' \preceq a'$  and for every  $c' \in [c]_{\Gamma}$  there must be an  $a' \in [a]_{\Gamma}$  s.t.  $a' \preceq c'$ .

Modularity: It is sufficient to prove that for every pair of individuals  $[a]_{\Gamma}, [b]_{\Gamma}$  in  $R'$ , either  $[a]_{\Gamma} \preceq^{R'} [b]_{\Gamma}$  or  $[b]_{\Gamma} \preceq^{R'} [a]_{\Gamma}$ , which is an immediate consequence of the definition of  $\preceq^{R'}$ .  $\square$

**Theorem 26 (FMP).** *Given a finite ontology  $\mathcal{K} = \langle \mathcal{T}, \mathcal{D} \rangle$ , if  $\mathcal{K}$  has a ranked model  $R$ , then it has a finite ranked model  $R'$ .*

*Proof.* Let  $\mathcal{K} = \langle \mathcal{T}, \mathcal{D} \rangle$  be a defeasible ontology,  $R$  a model of  $\mathcal{K}$  and  $R'$  a finite interpretation constructed from  $R$  as defined above. Let  $C \sqsupseteq D \in \mathcal{K}$ . Hence, either  $C^R = \emptyset$ , or the height of  $C \sqcap D$  in  $R$  is lower than the height of  $C \sqcap \neg D$ , that is, there is at least an individual  $b$  satisfying  $C \sqcap D$  s.t. for every individual  $a$  satisfying  $C \sqcap \neg D$ ,  $b \prec^R a$ . Since  $C, D$  and  $\neg D$  are in  $\Gamma$ , the individual  $[b]_{\Gamma} \in \Delta^{R'}$  (obtained from  $b \in \Delta^R$ , that hence satisfies  $C \sqcap D$ ) must be preferred to all the individuals satisfying  $C \sqcap \neg D$ , that is,  $[b]_{\Gamma} \prec^{R'} [a]_{\Gamma}$  for every individual  $[a]_{\Gamma}$  s.t.  $[a]_{\Gamma} \in (C \sqcap \neg D)^{R'}$ . Hence  $R' \models C \sqsupseteq D$ .  $\square$

1  
2  
3  
4  
5  
6  
7 We can obtain also the analogous *finite counter-model property*.

8 **Proposition 27** (FCMP). *Given a finite ontology  $\mathcal{K} = \langle \mathcal{T}, \mathcal{D} \rangle$  and an inclusion*  
9 *axiom  $C \sqsubseteq D$ , if  $\mathcal{K}$  has a ranked model  $R$  that is also a counter-model of  $C \sqsubseteq D$ , then*  
10 *it has a finite ranked model  $R'$  that is a counter-model of  $C \sqsubseteq D$ .*

11 *Proof.* It is sufficient to apply the same construction defined for the FMP: if  $R$  is not  
12 a model of  $C \sqsubseteq D$ , it means that there is an individual  $a$  s.t.  $R \models a:C \sqcap \neg D$  and  
13  $a \preceq_R b$  for every individual  $b$  s.t.  $R \models b:C \sqcap D$ . That implies that in  $R'$   $[a]_\Gamma \preceq_{R'} [b]_\Gamma$   
14 for every  $b$  s.t.  $R \models b:C \sqcap D$ , and consequently  $R' \not\models C \sqsubseteq D$ .  $\square$

## 15 Acknowledgments

16 Part of the work of Giovanni Casini has been supported by the Fonds National de la  
17 Recherche, Luxembourg, and cofunded by the Marie Curie Actions of the European  
18 Commission (FP7-COFUND) (AFR/9181001).

## 19 References

- 20  
21  
22  
23  
24  
25  
26  
27  
28 [1] Artale, A., Calvanese, D., Kontchakov, R., Zakharyashev, M., 2009. The DL-  
29 Lite family and relations. *J. of Artif. Intell. Res.* 36, 1–69.  
30  
31 [2] Baader, F., Brandt, S., Lutz, C., 2005. Pushing the  $\mathcal{EL}$  envelope. In: *Proceedings*  
32 *of the 19th International Joint Conference on Artificial Intelligence (IJCAI-05)*.  
33 Morgan-Kaufmann Publishers, Edinburgh, UK, pp. 364–369.  
34  
35 [3] Baader, F., Calvanese, D., McGuinness, D., Nardi, D., Patel-Schneider, P.  
36 (Eds.), 2007. *The Description Logic Handbook: Theory, Implementation and*  
37 *Applications*, 2nd Edition. Cambridge University Press.  
38  
39 [4] Baader, F., Hollunder, B., 1995. Embedding defaults into terminological knowl-  
40 edge representation formalisms. *J. of Automated Reason.* 14, 306–317.  
41  
42 [5] Baader, F., Hollunder, B., 1995. Priorities on defaults with prerequisites, and  
43 their application in treating specificity in terminological default logic. *J. of Au-*  
44 *tomated Reason.* 15, 41–68.  
45  
46 [6] Bonatti, P. A., Faella, M., Lutz, C., Sauro, L., Wolter, F., 2015. Decidability  
47 of circumscribed description logics revisited. In: *Advances in Knowledge Repre-*  
48 *sentation, Logic Programming, and Abstract Argumentation - Essays Dedicated*  
49 *to Gerhard Brewka on the Occasion of His 60th Birthday*. No. 9060 in LNCS.  
50 pp. 112–124.  
51  
52  
53  
54  
55  
56

- 1  
2  
3  
4  
5  
6  
7 [7] Bonatti, P. A., Faella, M., Petrova, I., Sauro, L., 2015. A new semantics for  
8 overriding in Description Logics. *Artif. Intell. J.* 222, 1–48.  
9  
10 [8] Bonatti, P. A., Faella, M., Sauro, L., 2011. Adding default attributes to EL++.  
11 In: *Proceedings of the 25th AAAI Conference on Artificial Intelligence (AAAI-*  
12 *11)*. AAAI Press.  
13  
14 [9] Bonatti, P. A., Faella, M., Sauro, L., 2011. Defeasible inclusions in low-  
15 complexity DLs. *J. of Artif. Intell. Res.* 42, 719–764.  
16  
17 [10] Bonatti, P. A., Lutz, C., Wolter, F., 2009. The complexity of circumscription in  
18 Description Logic. *J. Artif. Intell. Res.* 35 (1), 717–773.  
19  
20 [11] Booth, R., Paris, J. B., 1998. A note on the rational closure of knowledge bases  
21 with both positive and negative knowledge. *J. of Log., Lang. and Inf.* 7, 165–190.  
22  
23 [12] Britz, K., Casini, G., Meyer, T., Moodley, K., Varzinczak, I., 2013. Ordered in-  
24 terpretations and entailment for defeasible description logics. Tech. rep., CAIR,  
25 CSIR Meraka and UKZN, South Africa.  
26 URL <http://tinyurl.com/cydd6yy>  
27  
28 [13] Britz, K., Heidema, J., Meyer, T., 2008. Semantic preferential subsumption.  
29 In: Lang, J., Brewka, G. (Eds.), *Proceedings of the 11th International Confer-*  
30 *ence on Principles of Knowledge Representation and Reasoning (KR-08)*. AAAI  
31 Press/MIT Press, pp. 476–484.  
32  
33 [14] Britz, K., Meyer, T., Varzinczak, I., 2011. Semantic foundation for preferential  
34 Description Logics. In: Wang, D., Reynolds, M. (Eds.), *Proceedings of the 24th*  
35 *Australasian Joint Conference on Artificial Intelligence (AI-11)*. No. 7106 in  
36 *LNAI*. Springer, pp. 491–500.  
37  
38 [15] Cadoli, M., Donini, F. M., Schaerf, M., 1990. Closed world reasoning in hybrid  
39 systems. In: Ras, Z. W., Zemankova, M., Emrich, M. L. (Eds.), *Proc. of the 5th*  
40 *Int. Sym. on Methodologies for Intelligent Systems (ISMIS-90)*. North-Holland  
41 Publ. Co., Amsterdam, pp. 474–481.  
42  
43 [16] Casini, G., Meyer, T., Moodley, K., Nortjé, R., 2014. Relevant closure: A new  
44 form of defeasible reasoning for Description Logics. In: Fermé, E., Leite, J.  
45 (Eds.), *Proceedings of the 14th European Conference on Logics in Artificial*  
46 *Intelligence (JELIA-14)*. Vol. 8761 of *LNCS*. Springer, pp. 92–106.  
47  
48  
49  
50  
51  
52  
53  
54  
55  
56  
57  
58  
59  
60  
61  
62  
63  
64  
65

- 1  
2  
3  
4  
5  
6  
7 [17] Casini, G., Meyer, T., Moodley, K., Varzinczak, I., 2013. Nonmonotonic reasoning in Description Logics: Rational closure for the ABox. In: Proceedings of the 26th International Workshop on Description Logics (DL-13). pp. 600–615.  
8  
9  
10  
11 [18] Casini, G., Straccia, U., 2010. Rational closure for defeasible Description Logics. In: Janhunen, T., Niemelä, I. (Eds.), Proceedings of the 12th European Conference on Logics in Artificial Intelligence (JELIA-10). No. 6341 in LNCS. Springer-Verlag, pp. 77–90.  
12  
13  
14  
15  
16  
17 [19] Casini, G., Straccia, U., 2013. Defeasible inheritance-based Description Logics. J. of Artif. Intell. Res. 48, 415–473.  
18  
19  
20  
21 [20] Casini, G., Straccia, U., 2013. Towards rational closure for fuzzy logic: The case of propositional Gödel logic. In: Proceedings of the 19th International Conferences on Logic for Programming, Artificial Intelligence and Reasoning (LPAR-13). Vol. 8312 of LNCS. Springer Verlag, pp. 213–227.  
22  
23  
24  
25  
26 [21] Casini, G., Straccia, U., Forthcoming. Lexicographic closure for defeasible Description Logics. In: Proceedings of the 8th Australasian Ontology Workshop (AOW).  
27  
28  
29  
30  
31 [22] Donini, F. M., Nardi, D., Rosati, R., 1997. Autoepistemic Description Logics. In: Proceedings of the 15th International Joint Conference on Artificial Intelligence (IJCAI-97). pp. 136–141.  
32  
33  
34  
35  
36 [23] Donini, F. M., Nardi, D., Rosati, R., 2002. Description Logics of minimal knowledge and negation as failure. ACM Trans. on Comput. Log. 3, 177–225.  
37  
38  
39 [24] Eiter, T., Lukasiewicz, T., Schindlauer, R., Tompits, H., 2004. Combining answer set programming with Description Logics for the semantic web. In: Proceedings of the 9th International Conference on Principles of Knowledge Representation and Reasoning (KR-04). AAAI Press.  
40  
41  
42  
43  
44  
45 [25] Giordano, L., Gliozzi, V., Olivetti, N., Pozzato, G. L., 2009. Prototypical reasoning with low complexity Description Logics: Preliminary results. In: Proceedings of the 10th International Conference on Logic Programming and Nonmonotonic Reasoning (LPNMR-09). Vol. 5753 of LNCS. Springer-Verlag, Berlin, Heidelberg, pp. 430–436.  
46  
47  
48  
49  
50  
51  
52 [26] Giordano, L., Gliozzi, V., Olivetti, N., Pozzato, G. L., 2010. Preferential vs rational description logics: which one for reasoning about typicality? In: 19th  
53  
54  
55  
56  
57  
58  
59  
60  
61  
62  
63  
64  
65

1  
2  
3  
4  
5  
6  
7 European Conference on Artificial Intelligence (ECAI-10). Vol. 215 of Frontiers  
8 in Artificial Intelligence and Applications. IOS Press, pp. 1069–1070.

- 9  
10 [27] Giordano, L., Gliozzi, V., Olivetti, N., Pozzato, G. L., 2011. Reasoning about  
11 typicality in low complexity DLs: The logics  $EL^\perp t_{\min}$  and  $DL\text{-Lite}_c t_{\min}$ . In:  
12 Proceedings of the 22nd International Joint Conference on Artificial intelligence  
13 (IJCAI-11). IJCAI/AAAI, pp. 894–899.
- 14  
15 [28] Giordano, L., Gliozzi, V., Olivetti, N., Pozzato, G. L., 2011. A tableau cal-  
16 culus for a nonmonotonic extension of  $\mathcal{EL}^\perp$ . In: 20th International Confer-  
17 ence on Automated Reasoning with Analytic Tableaux and Related Methods  
18 (TABLEAUX-11). Vol. 6763 of LNCS. Springer Verlag, pp. 180–195.
- 19  
20 [29] Giordano, L., Gliozzi, V., Olivetti, N., Pozzato, G. L., 2012. A minimal model  
21 semantics for rational closure. In: Proceedings of the 14th International Work-  
22 shop on Nonmonotonic Reasoning (NMR-12).
- 23  
24 [30] Giordano, L., Gliozzi, V., Olivetti, N., Pozzato, G. L., 2012. Preferential low  
25 complexity description logics: Complexity results and proof methods. In: Pro-  
26 ceedings of the 2012 International Workshop on Description Logics (DL-12).  
27 Vol. 846 of CEUR Workshop Proceedings.
- 28  
29 [31] Giordano, L., Gliozzi, V., Olivetti, N., Pozzato, G. L., 2013. A non-monotonic  
30 description logic for reasoning about typicality. *Artif. Intell. J.* 195, 165–202.
- 31  
32 [32] Giordano, L., Gliozzi, V., Olivetti, N., Pozzato, G. L., 2014. Minimal models  
33 for rational closure in SHIQ. In: Proceedings of the 15th Italian Conference on  
34 Theoretical Computer Science (ICTCS-14). CEUR Workshop Proceedings. pp.  
35 271–277.
- 36  
37 [33] Giordano, L., Gliozzi, V., Olivetti, N., Pozzato, G. L., 2014. Rational closure  
38 in SHIQ. In: Proceedings of the 27th International Workshop on Description  
39 Logics (DL-14). CEUR Workshop Proceedings. pp. 543–555.
- 40  
41 [34] Giordano, L., Gliozzi, V., Olivetti, N., Pozzato, G. L., 2015. Semantic char-  
42 acterization of rational closure: From propositional logic to description logics.  
43 *Artif. Intell. J.* 226, 1–33.
- 44  
45 [35] Giordano, L., Olivetti, N., Gliozzi, V., Pozzato, G. L., 2012. A minimal model  
46 semantics for nonmonotonic reasoning. In: Fariñas del Cerro, L., Herzig, A.,  
47 Mengin, J. (Eds.), Proceedings of the 13th European Conference on Logics in  
48 Artificial Intelligence (JELIA-12). No. 7519 in LNCS. Springer, pp. 228–241.
- 49  
50  
51  
52  
53  
54  
55  
56  
57  
58  
59  
60  
61  
62  
63  
64  
65

- 1  
2  
3  
4  
5  
6  
7 [36] Giordano, L., Olivetti, N., Gliozzi, V., Pozzato, G. L., 2013. Minimal model  
8 semantics and rational closure in Description Logics. In: Proceedings of the  
9 26th International Workshop on Description Logics (DL-13).  
10  
11 [37] Grimm, S., Hitzler, P., 2009. A preferential tableaux calculus for circumscriptive  
12  $\mathcal{ALCO}$ . In: Proceedings of the 3rd International Conference on Web Reason-  
13 ing and Rule Systems (RR-09). Vol. 5837 of LNCS. Springer-Verlag, Berlin,  
14 Heidelberg, pp. 40–54.  
15  
16 [38] Hansson, S. O., 1999. A Textbook of Belief Dynamics. Theory Change and  
17 Database Updating. Kluwer.  
18  
19 [39] Horridge, M., 2011. Justification based explanation in ontologies. Ph.D. thesis,  
20 The University of Manchester.  
21  
22 [40] Kraus, S., Lehmann, D., Magidor, M., 1990. Nonmonotonic reasoning, prefer-  
23 ential models and cumulative logics. *Artif. Intell. J.* 44, 167–207.  
24  
25 [41] Lambrix, P., Shahmehri, N., Wahlloef, N., 1998. A default extension to Descrip-  
26 tion Logics for use in an intelligent search engine. In: Proceedings of the 31st  
27 Annual Hawaii International Conference on System Sciences (HICSS-98). IEEE  
28 Computer Society, Washington, DC, USA, p. 28.  
29  
30 [42] Lehmann, D., 1995. Another perspective on default reasoning. *Ann. of Math.*  
31 and *Artif. Intell.* 15 (1), 61–82.  
32  
33 [43] Lehmann, D., Magidor, M., 1992. What does a conditional knowledge base  
34 entail? *Artif. Intell. J.* 55, 1–60.  
35  
36 [44] Ludwig, M., Peñaloza, R., 2014. Error-tolerant reasoning in the description  
37 logic  $\mathcal{EL}$ . In: Fermé, E., Leite, J. (Eds.), Proceedings of the 14th European  
38 Conference on Logics in Artificial Intelligence (JELIA-14). Vol. 8761 of LNCS.  
39 Springer, pp. 107–121.  
40  
41 [45] Lukasiewicz, T., 2008. Expressive probabilistic Description Logics. *Artif. Intell.*  
42 *J.* 172 (6-7), 852–883.  
43  
44 [46] Lukasiewicz, T., 2008. Probabilistic description logic programs under inheritance  
45 with overriding for the semantic web. *Int. J. of Approx. Reason.* 49 (31), 18–34.  
46  
47 [47] Makinson, D., 2005. Bridges from Classical to Nonmonotonic Logic. Vol. 5 of  
48 Texts in Computing. King’s College Publications.  
49  
50  
51  
52  
53  
54  
55  
56  
57  
58  
59  
60  
61  
62  
63  
64  
65

- 1  
2  
3  
4  
5  
6 [48] OWL 2 Web Ontology Language Document Overview, 2009.  
7 <http://www.w3.org/TR/2009/REC-owl2-overview-20091027/>. W3C.  
8  
9  
10 [49] OWL 2 Web Ontology Language Profiles, 2009.  
11 <http://www.w3.org/TR/2009/REC-owl2-profiles-20091027/>. W3C.  
12  
13 [50] OWL 2 Web Ontology Language Profiles: OWL 2 EL, 2009.  
14 [http://www.w3.org/TR/2009/REC-owl2-profiles-20091027/#OWL\\_2\\_EL](http://www.w3.org/TR/2009/REC-owl2-profiles-20091027/#OWL_2_EL).  
15 W3C.  
16  
17  
18 [51] OWL 2 Web Ontology Language Profiles: OWL 2 RL, 2009.  
19 [http://www.w3.org/TR/2009/REC-owl2-profiles-20091027/#OWL\\_2\\_RL](http://www.w3.org/TR/2009/REC-owl2-profiles-20091027/#OWL_2_RL).  
20 W3C.  
21  
22  
23 [52] Quantz, J., 1992. A preference semantics for defaults in terminological logics.  
24 In: Proceedings of the 3rd International Conference on Principles of Knowledge  
25 Representation and Reasoning (KR-92). pp. 294–305.  
26  
27 [53] Stevens, R., Aranguren, M. E., Wolstencroft, K., Sattler, U., Drummond, N.,  
28 Horridge, M., Rector, A., 2007. Using OWL to model biological knowledge. *Int.*  
29 *J. of Human-Computer Stud.* 65 (7), 583 – 594.  
30  
31  
32 [54] Straccia, U., 1993. Default inheritance reasoning in hybrid KL-ONE-style logics.  
33 In: Proceedings of th 13th International Joint Conference on Artificial Intelli-  
34 gence (IJCAI-93). Chambery, France, pp. 676–681.  
35  
36  
37 [55] Touretzky, D. S., 1986. The mathematics of inheritance systems. Pitman, Lon-  
38 don, GB.  
39  
40  
41  
42  
43  
44  
45  
46  
47  
48  
49  
50  
51  
52  
53  
54  
55  
56  
57  
58  
59  
60  
61  
62  
63  
64  
65

---

**Procedure** LexicographicClosure( $\mathcal{K}, \alpha$ )
 

---

**Input:** Ontology  $\mathcal{K}$  and defeasible axiom  $\alpha$  of the form  $C \sqsubseteq D$ 
**Output:** true iff  $C \sqsubseteq D$  is in the Lexicographic Closure of  $\mathcal{K}$ 

```

1  1  $CL := \mathcal{T} \models C \sqsubseteq D$  // Check if  $\alpha$  holds classically;
2  2 if  $CL$  then
3  |   return  $CL$ 
4   $\langle \langle \mathcal{T}^*, \mathcal{D}^* \rangle, \{\mathcal{D}_0, \dots, \mathcal{D}_n\} \rangle := \text{ComputeRanking}(\mathcal{K})$ ;
5   $CL := \mathcal{T}^* \models C \sqsubseteq D$  // Check if  $\alpha$  holds classically, after finding strict knowledge in
6   $\mathcal{D}$ ;
7  6 if  $CL$  then
8  |   return  $CL$ 
9  // Compute  $C$ 's rank  $i$ ;
10  $i := 0$ ;  $\mathcal{D}_{\mathfrak{R}} := \mathcal{D}^*$ ;
11  $\mathcal{T}_{\delta_0} := \mathcal{T}^* \cup \{E \sqcap \delta_0 \sqsubseteq F \mid E \sqsubseteq F \in \mathcal{D}_{\mathfrak{R}}\}$ , where  $\delta_0$  is a new atomic concept;
12 while  $\mathcal{T}_{\delta_i} \models C \sqcap \delta_i \sqsubseteq \perp$  and  $\mathcal{D}_{\mathfrak{R}} \neq \emptyset$  do
13 |    $\mathcal{D}_{\mathfrak{R}} := \mathcal{D}_{\mathfrak{R}} \setminus \mathcal{D}_i$ ;  $i := i + 1$ ;
14 |    $\mathcal{T}_{\delta_i} := \mathcal{T}^* \cup \{E \sqcap \delta_i \sqsubseteq F \mid E \sqsubseteq F \in \mathcal{D}_{\mathfrak{R}}\}$ , where  $\delta_i$  is a new atomic concept;
15 // Check if  $\alpha$  holds under RC;
16  $RC := (\mathcal{T}_{\delta_i} \not\models C \sqcap \delta_i \sqsubseteq \perp) \wedge (\mathcal{T}_{\delta_i} \models C \sqcap \delta_i \sqsubseteq D)$ ;
17 if  $RC$  then
18 |   return  $RC$ 
19 // Compute  $\min_{C, \prec_{ser}}(\mathcal{D})$ ;
20 if  $i \leq n$  then
21 |    $\overline{\mathcal{D}} := \mathcal{D}_i \cup \dots \cup \mathcal{D}_n$ 
22 else
23 |    $\overline{\mathcal{D}} := \emptyset$ 
24  $k = i$ ,  $\min C_k := \{\overline{\mathcal{D}}\}$ ,  $\min C := \min C_k$ ;
25 while  $k > 0$  do
26 |    $\min C_{k-1} := \emptyset$ ;
27 |    $card := |\mathcal{D}_{k-1}|$ ,  $\min Card := 1$ ;
28 |   while  $card \geq \min Card$  do
29 |     foreach  $\Psi_j \subseteq \mathcal{D}_{k-1}$  s.t.  $|\Psi_j| = card$  do
30 |       foreach  $\Theta \in \min C$  do
31 |          $\Theta' = \Psi_j \cup \Theta$ ;
32 |          $\mathcal{T}_{\Theta'} := \mathcal{T}^* \cup \{E \sqcap \delta_{\Theta'} \sqsubseteq F \mid E \sqsubseteq F \in \Theta'\}$ , where  $\delta_{\Theta'}$  is a new atomic
33 |         concept;
34 |         if  $\mathcal{T}_{\Theta'} \not\models C \sqcap \delta_{\Theta'} \sqsubseteq \perp$  then
35 |            $\min C_{k-1} := \min C_{k-1} \cup \{\Theta'\}$ ;
36 |           if  $card > \min Card$  then
37 |              $\min Card := card$ 
38 |    $card := card - 1$ 
39 |   if  $\min C_{k-1} \neq \emptyset$  then
40 |      $\min C := \min C_{k-1}$ 
41 |    $k := k - 1$ 
42 // Check now if  $\alpha$  holds under LC;
43 if  $\min C = \min C_i$  then
44 |   return false // No change w.r.t. RC
45 foreach  $\Theta \in \min C$  do
46 |   if  $\mathcal{T}_{\Theta} \not\models C \sqcap \delta_{\Theta} \sqsubseteq D$  then
47 |     return false
48 return true

```

1  
2  
3  
4  
5  
6  
7  
8  
9  
10  
11  
12  
13  
14  
15  
16  
17  
18  
19  
20  
21  
22  
23  
24  
25  
26  
27  
28  
29  
30  
31  
32  
33  
34  
35  
36  
37  
38  
39  
40  
41  
42  
43  
44  
45  
46  
47  
48  
49  
50  
51  
52  
53  
54  
55  
56  
57  
58  
59  
60  
61  
62  
63  
64  
65

---

```

Procedure InheritanceBasedRationalClosure( $\mathcal{K}, \alpha$ )

---

  Input: Ontology  $\mathcal{K}$  and defeasible  $\mathcal{EL}^\perp$  axiom  $\alpha$ 
  Output: true iff  $\mathcal{K} \vdash_{in} \alpha$ 
  1  $\langle \mathcal{K}, \alpha \rangle := \text{Normalise}(\mathcal{K}, \alpha)$  //normalise both  $\mathcal{K}$  and  $\alpha$ ;
  2  $CTD := \text{RationalClosure}(\mathcal{K}, \top \sqsubseteq \perp)$  //Check if  $\mathcal{K}$  ranked inconsistent;
  3 if  $CTD$  then
  4   return  $CTD$ 
  5  $N_{\mathcal{K}} := \text{BuildInheritanceNet}(\mathcal{K})$  //Build inheritance net  $N_{\mathcal{K}}$  from  $\mathcal{K}$ ;
  6  $\mathcal{D}_{in} := \mathcal{D}$ ;
  7 foreach  $C, D \in N_{\mathcal{K}}$  do
  8    $\Delta_{C,D} :=$ 
  9    $\{E \rightarrow F \mid E \rightarrow F \text{ defeasible link occurring in a duct from } C \text{ to } D\}$ ;
 10   $\mathcal{D}' := \{E \sqsubseteq F \in \mathcal{D} \mid E \rightarrow F \in \Delta_{C,D}\}$ ;
 11   $\mathcal{K}' := \langle \mathcal{T}, \mathcal{D}' \rangle$ ;
 12  if  $\text{RationalClosure}(\mathcal{K}', C \sqsubseteq D)$  then
 13     $\mathcal{D}_{in} := \mathcal{D}_{in} \cup \{C \sqsubseteq D\}$ 
 14 // Check now if  $\alpha$  holds under Inheritance-Based RC;
 15  $\mathcal{K}_{in} := \langle \mathcal{T}, \mathcal{D}_{in} \rangle$ ;
 16  $IRC := \text{RationalClosure}(\mathcal{K}_{in}, \alpha)$ ;
 17 return  $IRC$ ;

---



```

1  
2  
3  
4  
5  
6  
7  
8  
9  
10  
11  
12  
13  
14  
15  
16  
17  
18  
19  
20  
21  
22  
23  
24  
25  
26  
27  
28  
29  
30  
31  
32  
33  
34  
35  
36  
37  
38  
39  
40  
41  
42  
43  
44  
45  
46  
47  
48  
49  
50  
51  
52  
53  
54  
55  
56  
57  
58  
59  
60  
61  
62  
63  
64  
65

---

**Procedure** BasicRelevantClosure( $\mathcal{K}, \alpha$ )

---

**Input:** Ontology  $\mathcal{K}$  and defeasible  $\mathcal{EL}^\perp$  axiom  $\alpha$  of the form  $C \sqsubseteq D$   
**Output:** true iff  $C \sqsubseteq D$  is in the Basic Relevant Closure of  $\mathcal{K}$

1  $CL := \mathcal{T} \models C \sqsubseteq D$  //Check if  $\alpha$  holds classically;  
2 **if**  $CL$  **then**  
3    $\lfloor$  **return**  $CL$   
4  $\langle \langle \mathcal{T}, \mathcal{D} \rangle, \{\mathcal{D}_0, \dots, \mathcal{D}_n\} \rangle := \text{ComputeRanking}(\mathcal{K})$ ;  
5  $CL := \mathcal{T} \models C \sqsubseteq D$  //Check if  $\alpha$  holds classically, after finding strict  
6 knowledge in  $\mathcal{D}$ ;  
7 **if**  $CL$  **then**  
8    $\lfloor$  **return**  $CL$   
9  $\{\mathcal{J}_1, \dots, \mathcal{J}_m\} := \text{ComputeJustifications}(\mathcal{K}, C)$ ;  
10  $\overline{\mathcal{J}} := \bigcup_{j=1}^m \mathcal{J}_j$ ;  
11  $i := 0$ ,  $exit := \text{false}$ ;  
12 **repeat**  
13    $\mathcal{J}'_i := \mathcal{J} \cap \bigcup_{j \geq i} \mathcal{D}_j$ ;  
14    $CL :=$   
15    $T \cup \{E \sqcap \delta \sqsubseteq F \mid E \sqsubseteq F \in \mathcal{D} \setminus \overline{\mathcal{J}}\} \cup \{E \sqcap \delta \sqsubseteq F \mid E \sqsubseteq F \in \mathcal{J}'_i\} \models C \sqcap \delta \sqsubseteq \perp$ ;  
16   **if**  $CL$  **and**  $(i < n)$  **then**  
17      $\lfloor$   $i := i + 1$   
18   **else**  
19     **if**  $CL$  **and**  $(i = n)$  **then**  
20        $\mathcal{J}'_i := \emptyset$ ;  
21        $exit := \text{true}$   
22     **else**  
23        $\lfloor$   $exit := \text{true}$   
24 **until**  $exit$ ;  
25  $BRC :=$   
26  $T \cup \{E \sqcap \delta \sqsubseteq F \mid E \sqsubseteq F \in \mathcal{D} \setminus \overline{\mathcal{J}}\} \cup \{E \sqcap \delta \sqsubseteq F \mid E \sqsubseteq F \in \mathcal{J}'_i\} \models C \sqcap \delta \sqsubseteq D$ ;  
27 **return**  $BRC$ ;

---

---

```

9 Procedure MinimalRelevantClosure( $\mathcal{K}, \alpha$ )

---

10 Input: Ontology  $\mathcal{K}$  and defeasible  $\mathcal{EL}^\perp$  axiom  $\alpha$  of the form  $C \sqsubseteq D$ 
11 Output: true iff  $C \sqsubseteq D$  is in the Minimal Relevant Closure of  $\mathcal{K}$ 
12
13 1  $CL := \mathcal{T} \models C \sqsubseteq D$  //Check if  $\alpha$  holds classically;
14
15 2 if  $CL$  then
16   3  $\lfloor$  return  $CL$ 
17
18 4  $\langle\langle \mathcal{T}, \mathcal{D} \rangle, \{\mathcal{D}_0, \dots, \mathcal{D}_n\}\rangle := \text{ComputeRanking}(\mathcal{K})$ ;
19 5  $CL := \mathcal{T} \models C \sqsubseteq D$  //Check if  $\alpha$  holds classically, after finding strict
20   knowledge in  $\mathcal{D}$ ;
21
22 6 if  $CL$  then
23   7  $\lfloor$  return  $CL$ 
24
25 8  $\{\mathcal{J}^1, \dots, \mathcal{J}^m\} := \text{ComputeJustifications}(\mathcal{K}, C)$ ;
26 9 foreach  $\mathcal{J}^j$  do
27   10  $\lfloor \mathcal{J}_{\min}^j := \{D \sqsubseteq E \in \mathcal{J}^j \mid r_{\mathcal{K}}(D) \leq r_{\mathcal{K}}(F) \text{ for every } F \sqsubseteq G \in \mathcal{J}^j\}$ ;
28
29 11  $\mathcal{J}_{\min} := \bigcup_{j=1}^m \mathcal{J}_{\min}^j$ ;
30 12  $i := 0$ ,  $exit := \text{false}$ ;
31
32 13 repeat
33   14  $\mathcal{J}'_i := \mathcal{J} \cap \bigcup_{j \geq i} \mathcal{D}_j$ ;
34   15  $CL :=$ 
35      $\mathcal{T} \cup \{E \sqcap \delta \sqsubseteq F \mid E \sqsubseteq F \in \mathcal{D} \setminus \mathcal{J}_{\min}\} \cup \{E \sqcap \delta \sqsubseteq F \mid E \sqsubseteq F \in \mathcal{J}'_i\} \models C \sqcap \delta \sqsubseteq \perp$ ;
36   16 if  $CL$  and  $(i < n)$  then
37     17  $\lfloor i := i + 1$ 
38
39   18 else
40     19 if  $CL$  and  $(i = n)$  then
41       20  $\lfloor \mathcal{J}'_i := \emptyset$ ;
42       21  $\lfloor exit := \text{true}$ 
43
44     22 else
45       23  $\lfloor exit := \text{true}$ 
46
47 24 until  $exit$ ;
48 25  $MRC :=$ 
49    $\mathcal{T} \cup \{E \sqcap \delta \sqsubseteq F \mid E \sqsubseteq F \in \mathcal{D} \setminus \mathcal{J}_{\min}\} \cup \{E \sqcap \delta \sqsubseteq F \mid E \sqsubseteq F \in \mathcal{J}'_i\} \models C \sqcap \delta \sqsubseteq D$ ;
50 26 return  $MRC$ ;

---



```